

**332**

**Advanced Computer Architecture  
Chapter 5**

**Instruction Level Parallelism  
- the static scheduling approach**

**February 2010**

**Paul H J Kelly**

**These lecture notes are partly based on the course text, Hennessy and Patterson's *Computer Architecture, a quantitative approach* (3<sup>rd</sup> and 4<sup>th</sup> eds), and on the lecture slides of David Patterson and John Kubiawicz's Berkeley course**

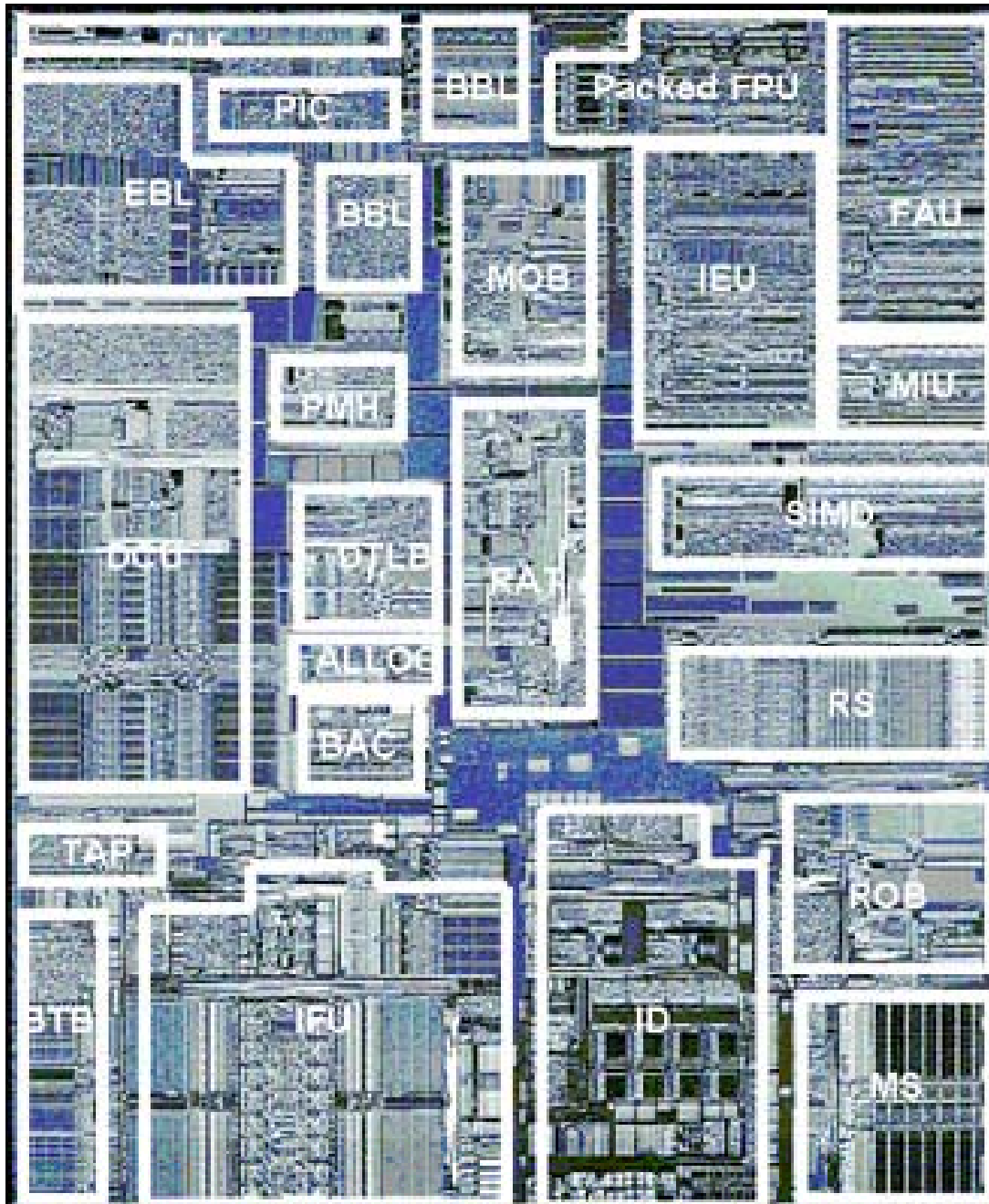

Intel Pentium III

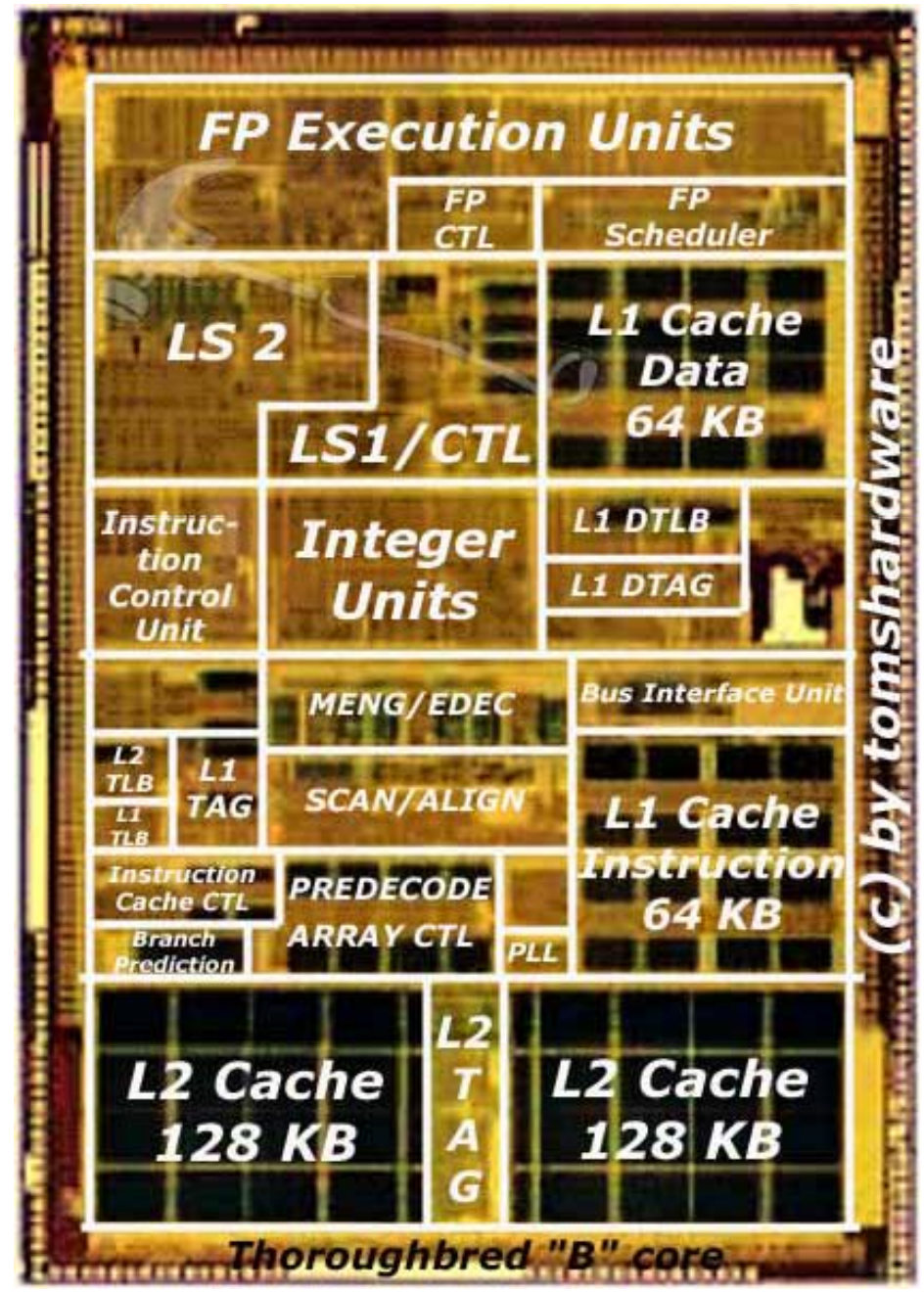

AMD Athlon CPU core

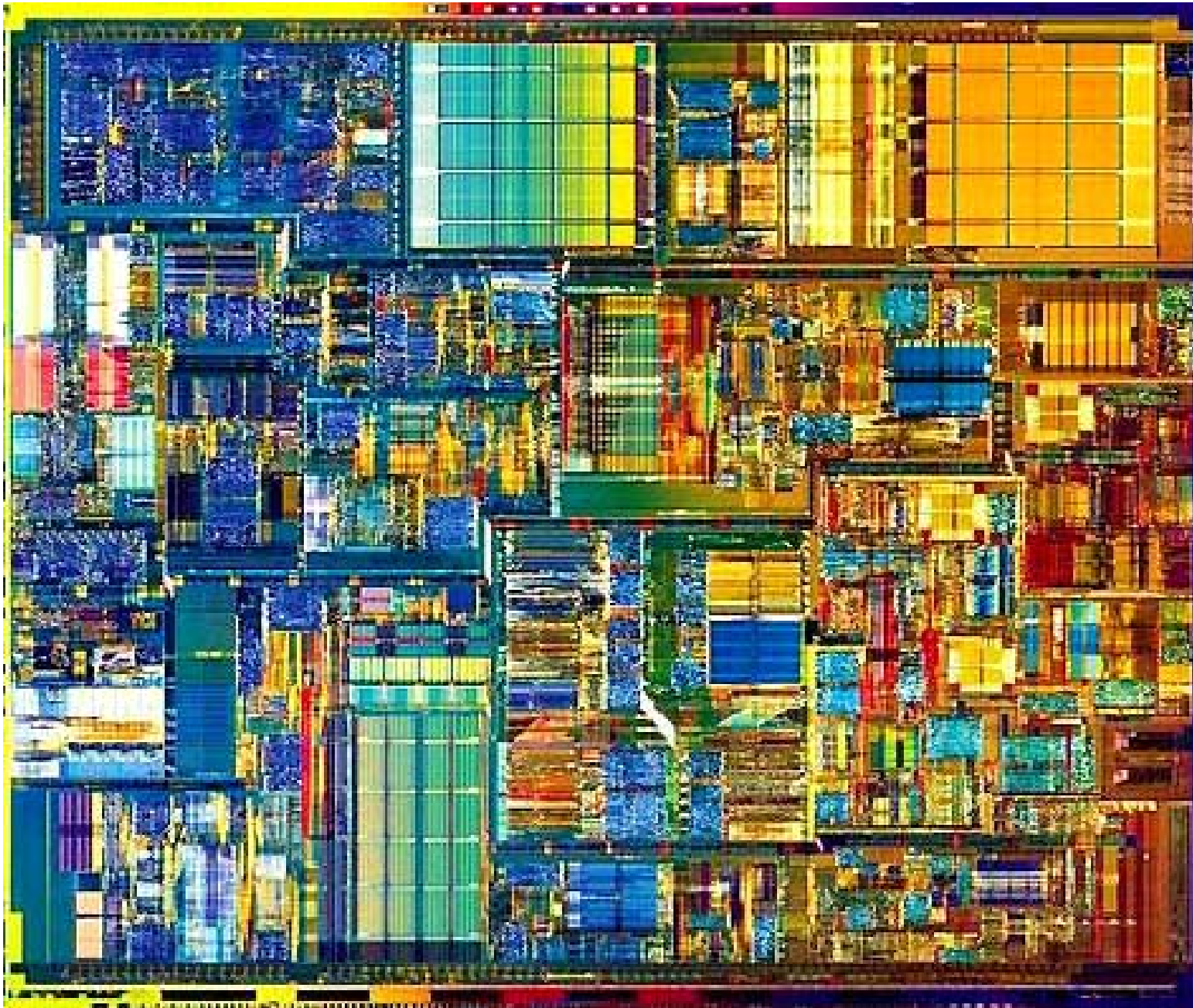

- ▶ 42M transistors
- ▶ 1.5GHz
- ▶ 180nm process
- ▶ 8K L1
- ▶ 256K L2

▶ Intel 2000 - Pentium 4 "Netburst"

# Intel Core 2 Duo

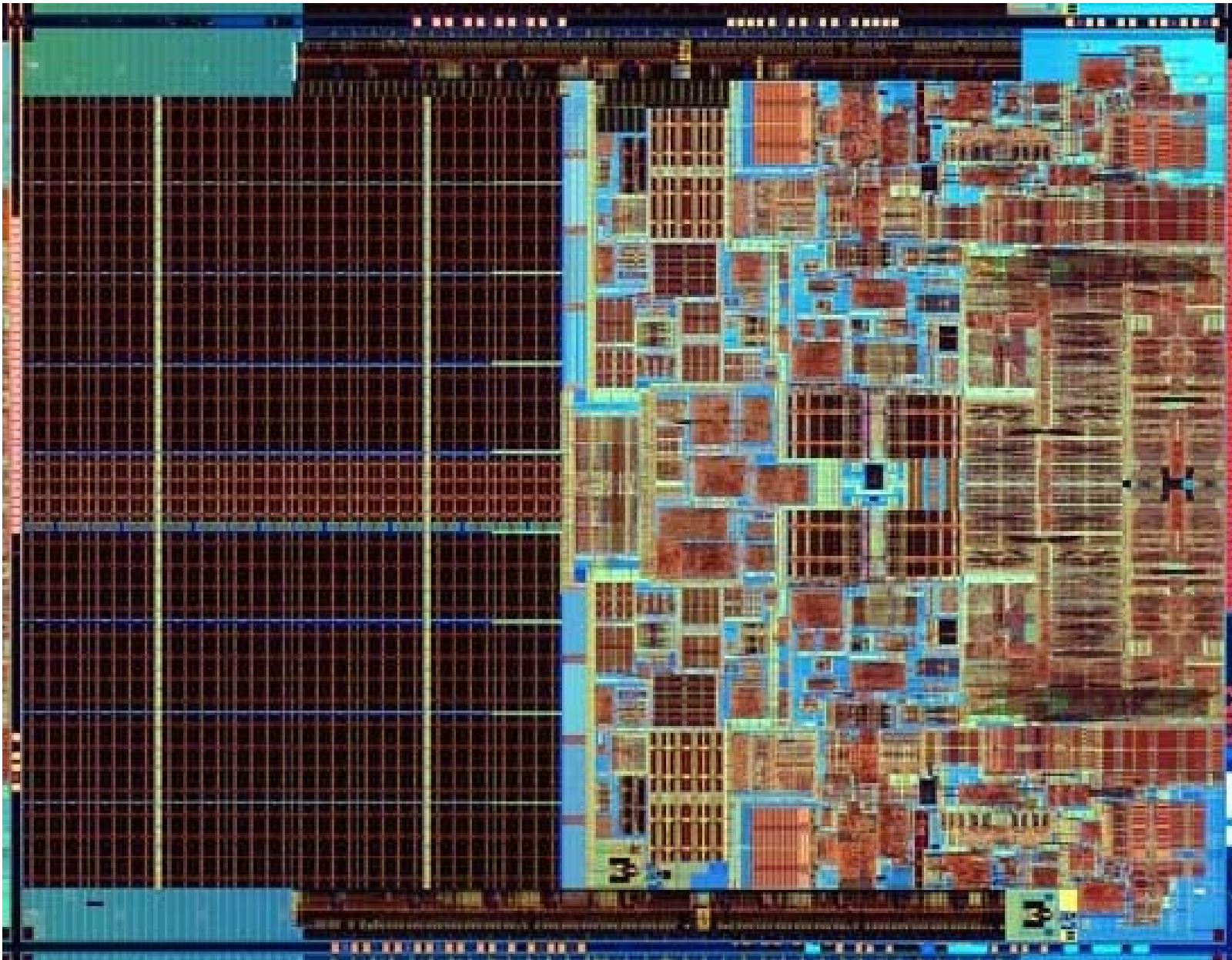

- Two cores/die
- 291M transistors
- 1.8-3.0 GHz
- 65nm process
- 4MB L2
- 65W

## Intel 2006 - Tulsa: dual-core Pentium 4 ("Netburst") with shared L3

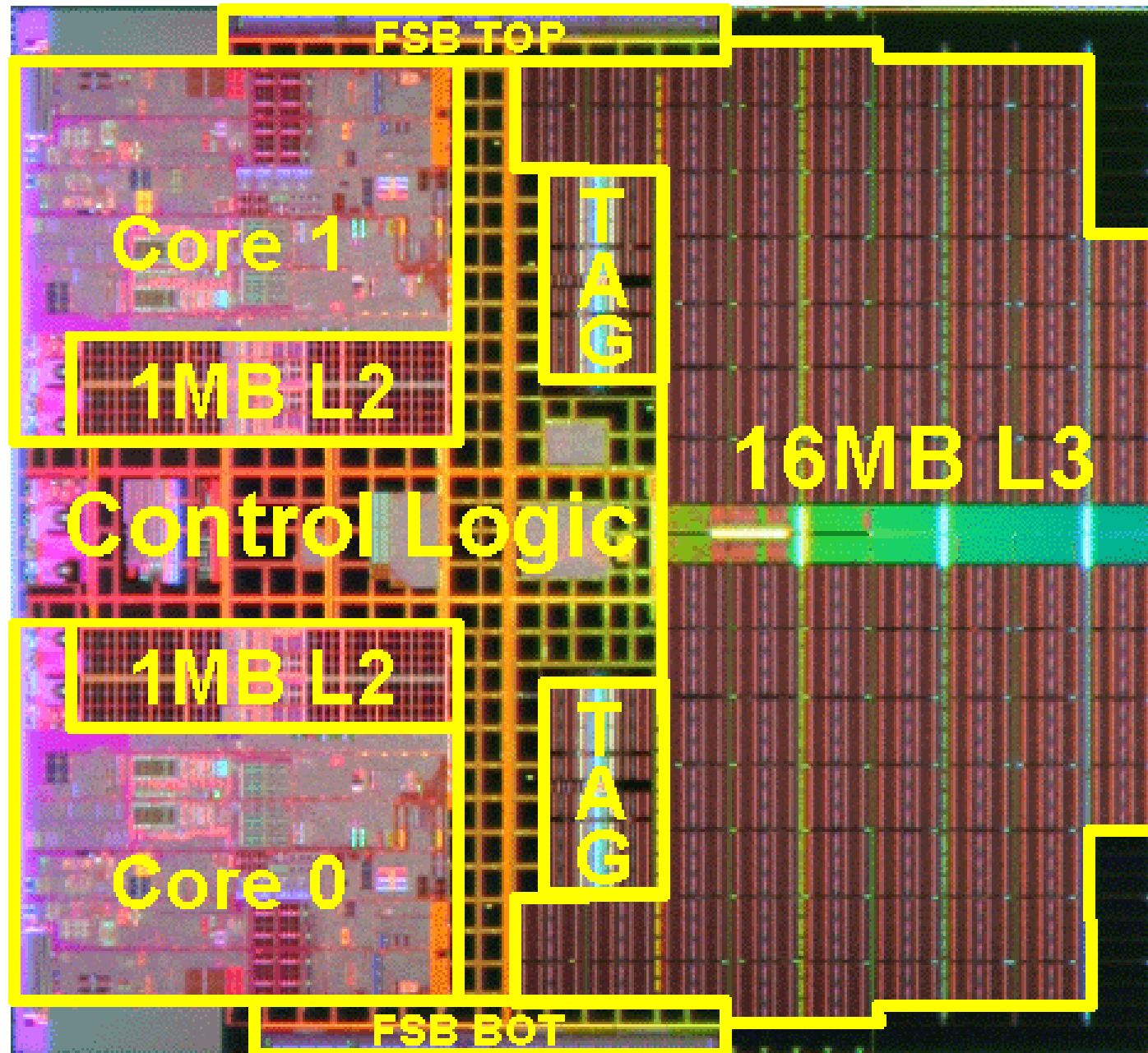

- ▶ 1MB L2 cache per core
- ▶ 16MB of inclusive shared L3 cache
- ▶ 1.3B transistors (121M/core)
- ▶ 435mm<sup>2</sup> in 65nm with 8 layers of copper interconnect
- ▶ 3.4GHz with 1.25V, and a 150W TDP and 110W average power.

▶ <http://www.realworldtech.com/page.cfm?ArticleID=RWT021906030756>

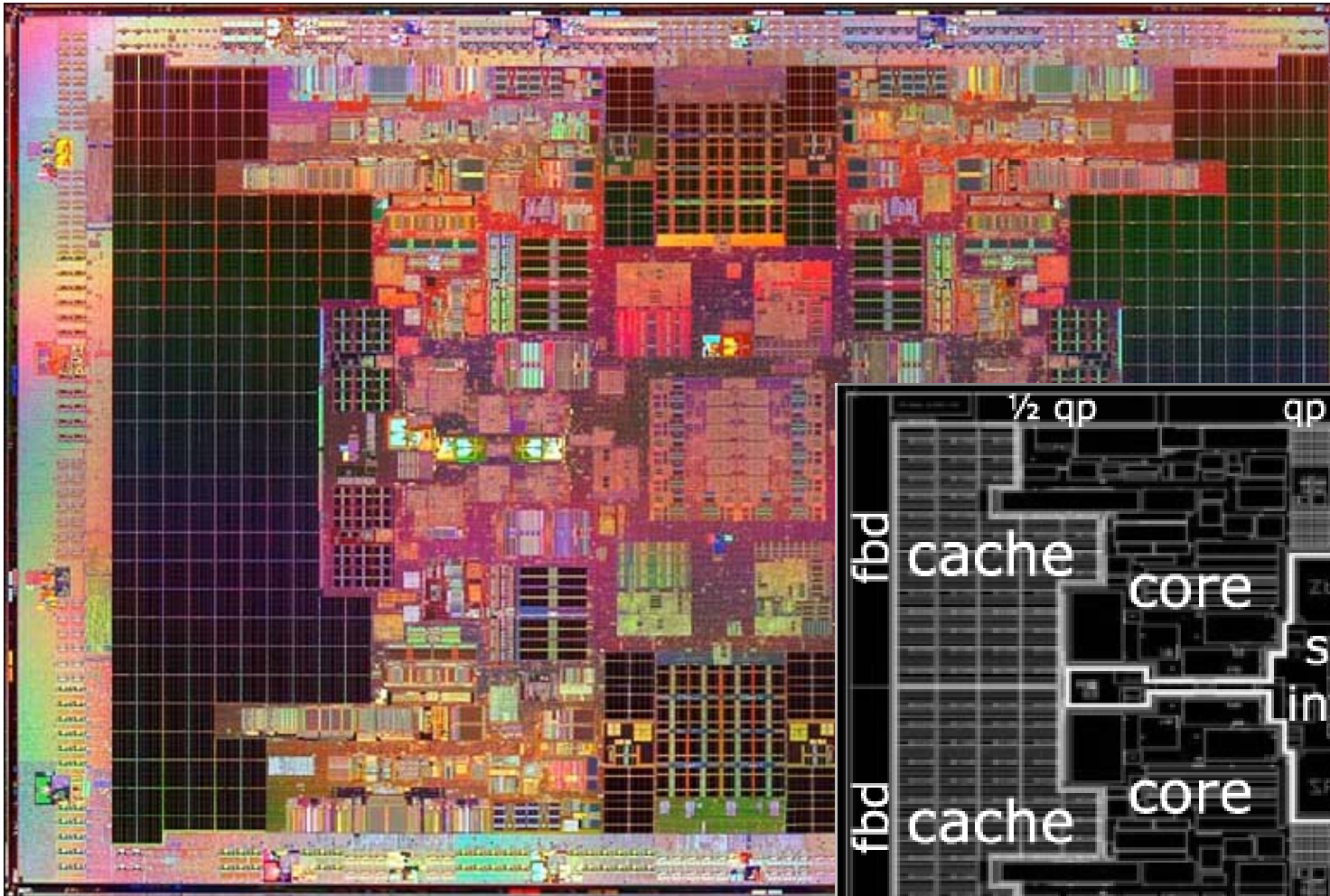

## Intel 2008: Tukwila

- ▶ Quad-core
- ▶ IA-64
- ▶ 30MB L2

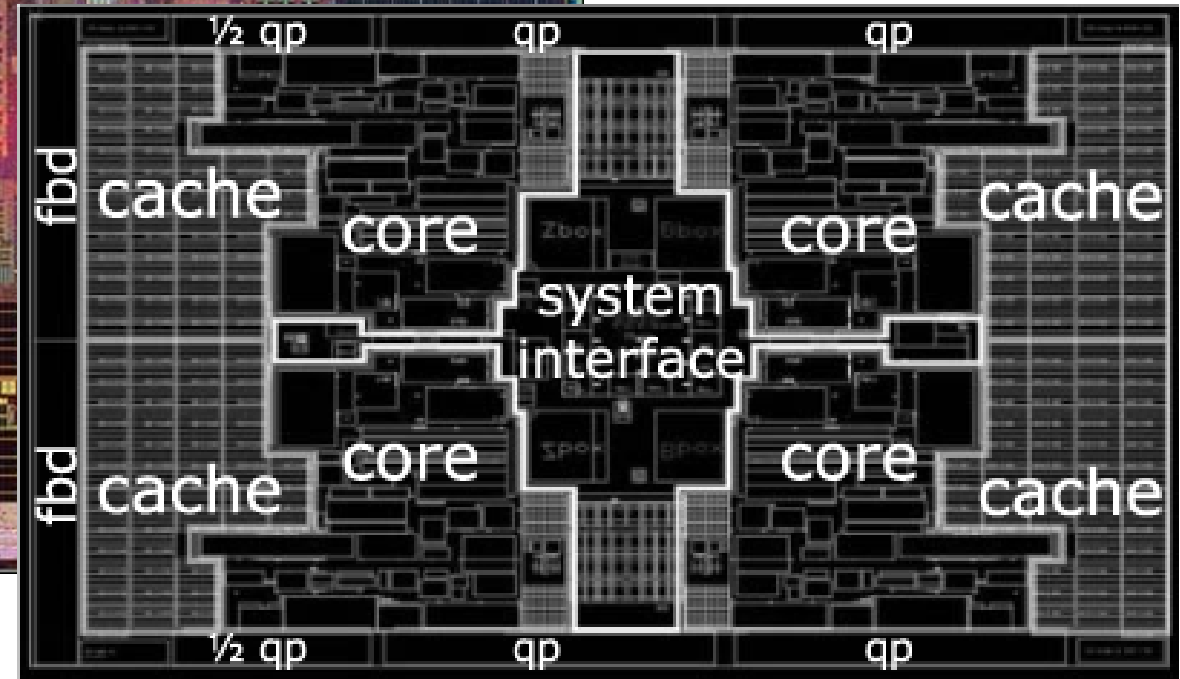

▶ 2B transistors

▶ 2GHz

▶ 170W

▶ 65nm

	FET count	Voltage	Power
Core logic	430M	0.9-1.15V	100W
Sys Int	157M	0.9-1.15V	30W
L3 cache	1,420M	1.10V	20W
IO logic	39M	1.10V	20W
<b>Chip Total</b>	<b>2.046B</b>		<b>170W</b>

# nVidia 2008

- ▶ nVidia G200
- ▶ 1.4B transistors
- ▶ 65nm
- ▶ 576mm<sup>2</sup> (apparently)
- ▶ max thermal design power (TDP): 236W
- ▶ Cards sell for around £320

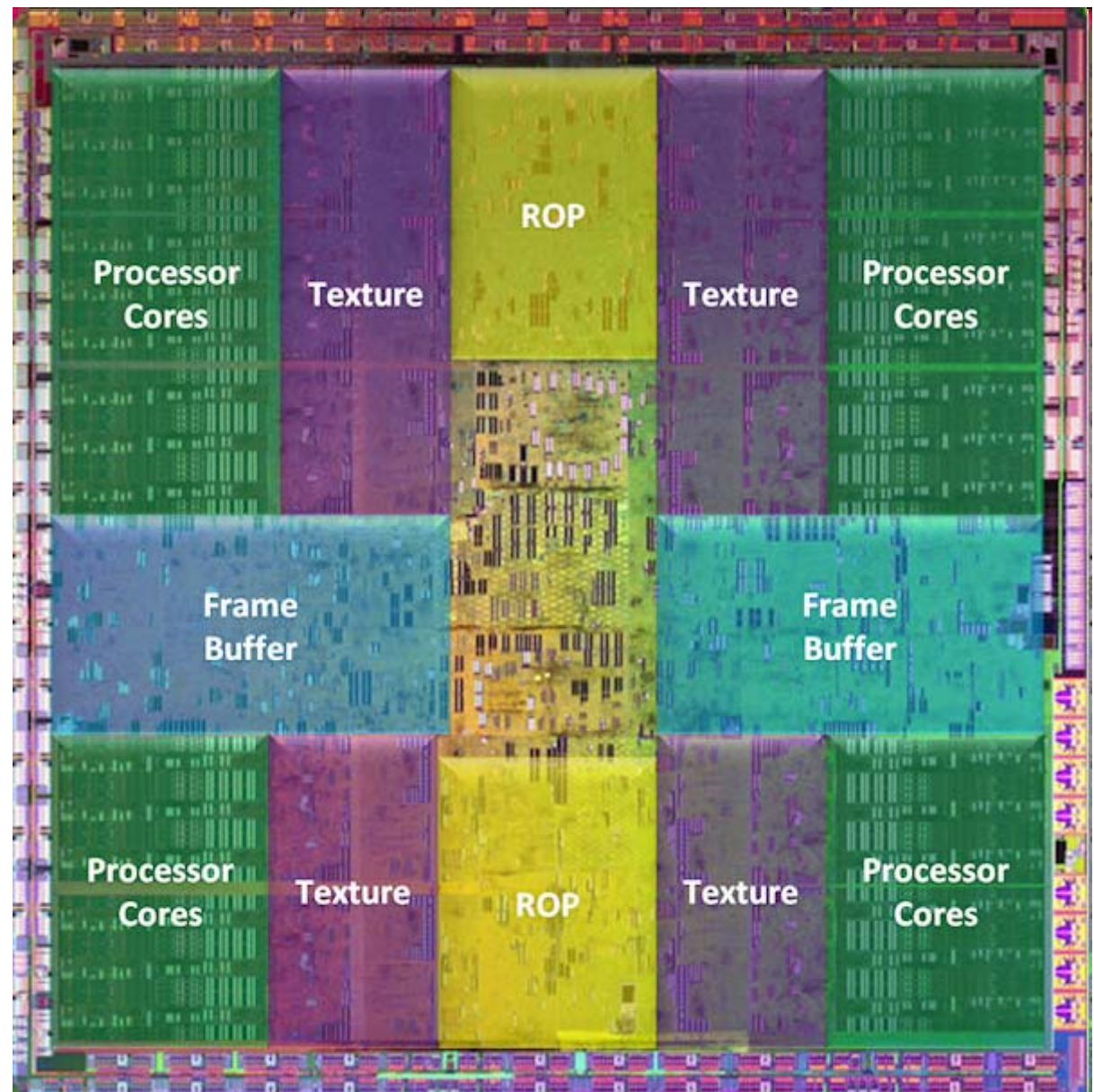

## Performance advice example: Pentium 4 memory aliasing

“There are several cases where addresses with a given stride will compete for some resource in the memory hierarchy. Note that first-level cache lines are 64 bytes and second-level cache lines are 128 bytes. Thus the least significant 6 or 7 bits are not considered in alias comparisons. The aliasing cases are listed below.

- 2K for data – map to the same first-level cache set (32 sets, 64-byte lines). There are 4 ways in the first-level cache, so if there are more than 4 lines that alias to the same 2K modulus in the working set, there will be an excess of first-level cache misses.
- 16K for data – will look same to the store-forwarding logic. If there has been a store to an address which aliases with the load, the load will stall until the store data is available.
- 16K for code – can only be one of these in the trace cache at a time. If two traces whose starting addresses are 16K apart are in the same working set, the symptom will be a high trace cache miss rate. Solve this by offsetting one of the addresses by 1 or more bytes.
- 32K for code or data – map to the same second-level cache set (256 sets, 128-byte lines). There are 8 ways in the second-level cache, so if there are more than 8 lines that alias to the same 32K modulus in the working set, there will be an excess of second-level cache misses.
- 64K for data – can only be one of these in the first-level cache at a time. If a reference (load or store) occurs that has bits 0-15 of the linear address, which are identical to a reference (load or store) which is underway, then second reference cannot begin until first one is kicked out of cache. Avoiding this kind of aliasing can lead to a factor of three speedup.” (<http://www.intel.com/design/pentium4/manuals/24896607.pdf> page 2-38)

# Review: extreme dynamic ILP

## ▶ P6 (Pentium Pro, II, III, AMD Athlon)

- ▶ Translate most 80x86 instructions to micro-operations
  - Longer pipeline than RISC instructions
- ▶ Dynamically execute micro-operations

## ▶ “Netburst” (Pentium 4, ...)

- ▶ Much longer pipeline, higher clock rate in same technology as P6
- ▶ Trace Cache to capture micro-operations, avoid hardware translation

## ▶ Intel “Next Generation Microarchitecture” (Pentium M, Core, Core 2 Duo)

- ▶ Shorter pipeline, wider issue, high-bandwidth smart decode instead of trace cache

## ▶ How can we take these ideas further?

- ▶ Complexity of issuing multiple instructions per cycle
- ▶ And of committing them
  - n-way multi-issue processor with an m-instruction dynamic scheduling window
  - m must increase if n is increased
  - Need n register ports
  - Need to compare each of the n instruction’s src and dst regs to determine dependence
- ▶ Predicting and speculating across multiple branches
- ▶ With many functional units and registers, wires will be long – need pipeline stage just to move the data across the chip

# Overview

- ▶ **The previous Chapter: Dynamic scheduling, out-of-order (o-o-o): binary compatible, exploiting ILP in hardware: BTB, ROB, Reservation Stations, ...**
- ▶ **How much of all this complexity can you shift into the compiler?**
- ▶ **What if you can also change instruction set architecture?**
- ▶ **VLIW (Very Long Instruction Word)**
- ▶ **EPIC (Explicitly Parallel Instruction Computer)**
  - ▶ **Intel's (and HP's) multi-billion dollar gamble for the future of computer architecture: Itanium, IA-64**
  - ▶ **Started ca.1994...not dead yet – but has it turned a profit?**

# Running Example

▀ This code adds a scalar to a vector:

```
for (i=1000; i>=0; i=i-1)
```

```
    x[i] = x[i] + s;
```

▀ Assume following latency all examples

<i>Instruction producing result</i>	<i>Instruction using result</i>	<i>Execution in cycles</i>	<i>Latency in cycles</i>
FP ALU op	Another FP ALU op	4	3
FP ALU op	Store double	3	2
Load double	FP ALU op	1	1
Load double	Store double	1	0
Integer op	Integer op	1	0

# FP Loop: Where are the Hazards?

- **First translate into MIPS code:**

-To simplify, assume 8 is lowest address

```
Loop:  L.D      F0,0(R1)  ;F0=vector element
        ADD.D   F4,F0,F2  ;add scalar from F2
        S.D     0(R1),F4  ;store result
        DSUBUI  R1,R1,8   ;decrement pointer 8B (DW)
        BNEZ   R1,Loop   ;branch R1!=zero
        NOP                ;delayed branch slot
```

**Where are the stalls?**

# FP Loop Showing Stalls

```
1 Loop: L.D    F0,0(R1) ;F0=vector element
2          stall
3          ADD.D F4,F0,F2 ;add scalar in F2
4          stall
5          stall
6          S.D   0(R1),F4 ;store result
7          DSUBUI R1,R1,8 ;decrement pointer 8B (DW)
8          BNEZ  R1,Loop ;branch R1!=zero
9          stall          ;delayed branch slot
```

<i>Instruction producing result</i>	<i>Instruction using result</i>	<i>Latency in clock cycles</i>
FP ALU op	Another FP ALU op	3
FP ALU op	Store double	2
Load double	FP ALU op	1

 **9 clocks: Rewrite code to minimize stalls?**

# Revised FP Loop Minimizing Stalls

```
1 Loop: L.D    F0,0(R1)
2          stall
3          ADD.D F4,F0,F2
4          DSUBUI R1,R1,8
5          BNEZ  R1,Loop ;delayed branch
6          S.D   8(R1),F4 ;altered when move past DSUBUI
```

## Swap BNEZ and S.D by changing address of S.D

<i>Instruction producing result</i>	<i>Instruction using result</i>	<i>Latency in clock cycles</i>
FP ALU op	Another FP ALU op	3
FP ALU op	Store double	2
Load double	FP ALU op	1

**6 clocks, but just 3 for execution, 3 for loop overhead; How make faster?**

# Unroll Loop Four Times (straightforward way)

```
1 Loop:L.D    F0,0(R1)
2      ADD.D  F4,F0,F2
3      S.D    0(R1),F4
4      L.D    F6,-8(R1)
5      ADD.D  F8,F6,F2
6      S.D    -8(R1),F8
7      L.D    F10,-16(R1)
8      ADD.D  F12,F10,F2
9      S.D    -16(R1),F12
10     L.D    F14,-24(R1)
11     ADD.D  F16,F14,F2
12     S.D    -24(R1),F16
13     DSUBUI R1,R1,#32
14     BNEZ   R1,LOOP
15     NOP
```

← 1 cycle stall  
← 2 cycles stall

*;drop DSUBUI & BNEZ*  
*;drop DSUBUI & BNEZ*  
*;drop DSUBUI & BNEZ*  
*;alter to 4\*8*

**Rewrite loop to  
minimize stalls?**

*15 + 4 x (1+2) = 27 clock cycles, or 6.8 per iteration*  
*Assumes R1 is multiple of 4*

# Unroll the loop four times

- Four copies of the loop body
- One copy of increment and test
- Adjust register-indirect loads using offsets

```
1 Loop: L.D    F0, 0(R1)
2      ADD.D   F4, F0, F2
3      S.D    0(R1), F4      ;drop DSUBUI & BNEZ
4      L.D    F0, -8(R1)
5      ADD.D   F4, F0, F2
6      S.D    -8(R1), F4     ;drop DSUBUI & BNEZ
7      L.D    F0, -16(R1)
8      ADD.D   F4, F0, F2
9      S.D    -16(R1), F4   ;drop DSUBUI & BNEZ
10     L.D    F0, -24(R1)
11     ADD.D   F4, F0, F2
12     S.D    -24(R1), F4
13     DSUBUI  R1, R1, #32   ;alter to 4*8
14     BNEZ   R1, LOOP
15     NOP
```

- Re-use of registers creates WAR (“anti-dependences”)
  - How can we remove them?

# Loop unrolling...

```
1 Loop:L.D    F0,0(R1)
2      ADD.D  F4,F0,F2
3      S.D    0(R1),F4      ;drop DSUBUI & BNEZ
4      L.D    F6,-8(R1)
5      ADD.D  F8,F6,F2
6      S.D    -8(R1),F8     ;drop DSUBUI & BNEZ
7      L.D    F10,-16(R1)
8      ADD.D  F12,F10,F2
9      S.D    -16(R1),F12  ;drop DSUBUI & BNEZ
10     L.D    F14,-24(R1)
11     ADD.D  F16,F14,F2
12     S.D    -24(R1),F16
13     DSUBUI R1,R1,#32     ;alter to 4*8
14     BNEZ   R1,LOOP
15     NOP
```

The original “register renaming”

# Unrolled Loop That Minimizes Stalls

```
1 Loop: L.D    F0, 0(R1)
2       L.D    F6, -8(R1)
3       L.D    F10, -16(R1)
4       L.D    F14, -24(R1)
5       ADD.D  F4, F0, F2
6       ADD.D  F8, F6, F2
7       ADD.D  F12, F10, F2
8       ADD.D  F16, F14, F2
9       S.D    0(R1), F4
10      S.D    -8(R1), F8
11      S.D    -16(R1), F12
12      DSUBUI R1, R1, #32
13      BNEZ   R1, LOOP
14      S.D    8(R1), F16 ; 8-32 = -24
```

## What assumptions made when moved code?

- ➔ OK to move store past DSUBUI even though changes register
- ➔ OK to move loads before stores: get right data?
- ➔ When is it safe for compiler to do such changes?

*14 clock cycles, or 3.5 per iteration*

# Compiler Perspectives on Code Movement

## ▶ Name Dependencies are Hard to discover for Memory Accesses

- ▶ Does  $100(R4) = 20(R6)$ ?
- ▶ From different loop iterations, does  $20(R6) = 20(R6)$ ?
- ▶ Need to solve the “dependence equation”

## ▶ Our example required compiler to know that if R1 doesn't change then:

$$0(R1) \neq -8(R1) \neq -16(R1) \neq -24(R1)$$

There were no dependencies between some loads and stores so they could be moved by each other

# Steps Compiler Performed to Unroll

- ▶ Check OK to move the S.D after DSUBUI and BNEZ, and find amount to adjust S.D offset
- ▶ Determine unrolling the loop would be useful by finding that the loop iterations were independent
- ▶ Rename registers to avoid name dependencies
- ▶ Eliminate extra test and branch instructions and adjust the loop termination and iteration code
- ▶ Determine loads and stores in unrolled loop can be interchanged by observing that the loads and stores from different iterations are independent
  - ▶ requires analyzing memory addresses and finding that they do not refer to the same address.
- ▶ Schedule the code, preserving any dependences needed to yield same result as the original code

# Another possibility: Software Pipelining

- ▶ Observation: if iterations from loops are independent, then can get more ILP by taking instructions from different iterations
- ▶ Software pipelining: reorganizes loops so that each iteration is made from instructions chosen from different iterations of the original loop (~ Tomasulo in SW)

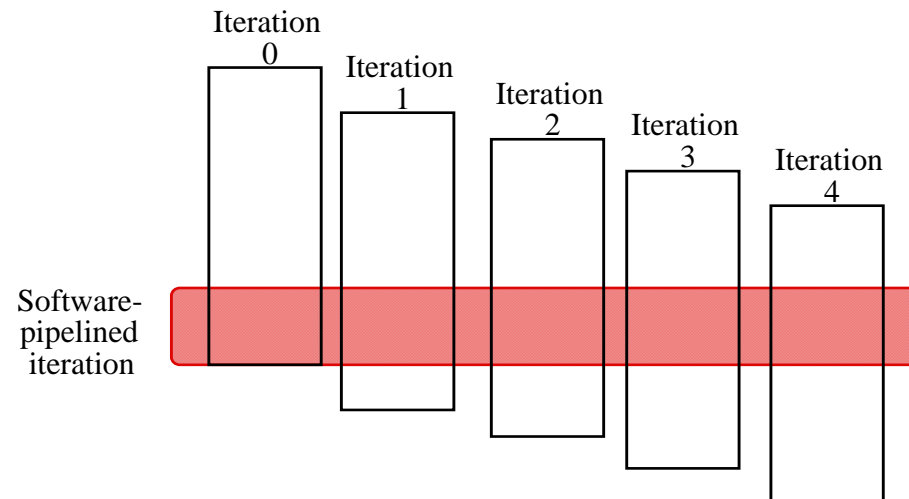

# Software Pipelining Example

Before: Unrolled 3 times

```

1  L.D   F0,0(R1)
2  ADD.D F4,F0,F2
3  S.D   0(R1),F4
4  L.D   F6,-8(R1)
5  ADD.D F8,F6,F2
6  S.D   -8(R1),F8
7  L.D   F10,-16(R1)
8  ADD.D F12,F10,F2
9  S.D   -16(R1),F12
10 DSUBUI R1,R1,#24
11 BNEZ  R1,LOOP
    
```

After: Software Pipelined

```

1  S.D   0(R1),F4 ; Stores M[i]
2  ADD.D F4,F0,F2 ; Adds to M[i-1]
3  L.D   F0,-16(R1); Loads M[i-2]
4  DSUBUI R1,R1,#8
5  BNEZ  R1,LOOP
    
```

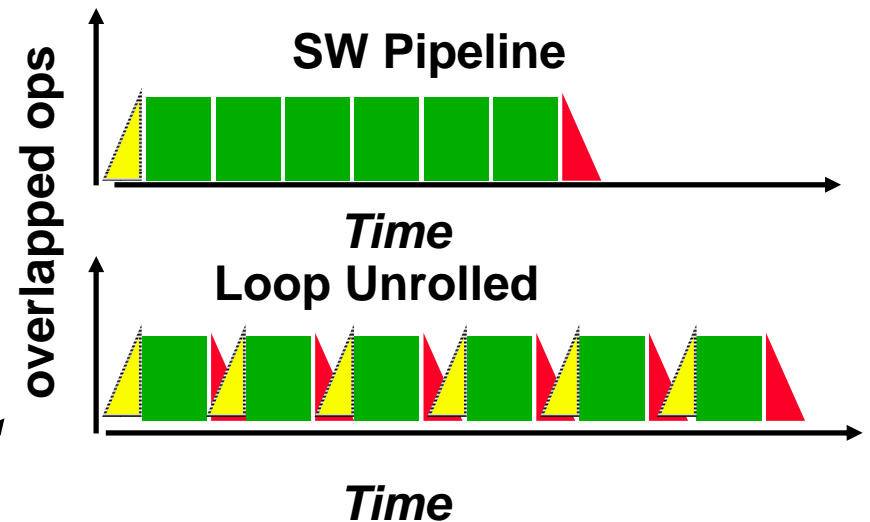

- **Symbolic Loop Unrolling**

- Maximize result-use distance
- Less code space than unrolling
- Fill & drain pipe only once per loop  
vs. once per each unrolled iteration in loop unrolling

*5 cycles per iteration*

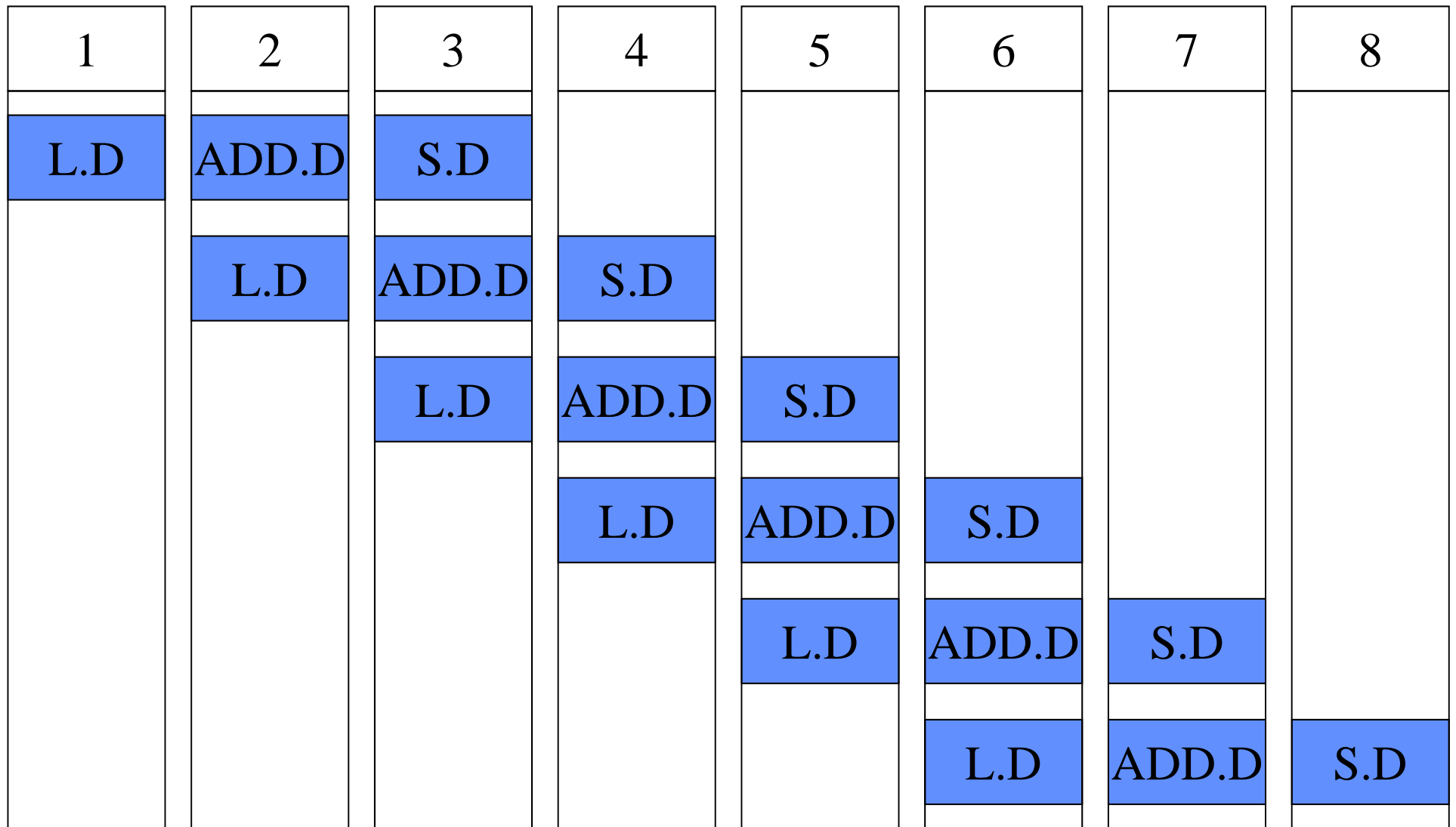

Pipeline fills



Pipeline full



Pipeline drains

# Loop-carried dependences

Example: Where are data dependencies?  
(A,B,C distinct & non-overlapping)

```
for (i=0; i<100; i=i+1) {  
    A[i+1] = A[i] + C[i]; /* S1 */  
    B[i+1] = B[i] + A[i+1]; /* S2 */  
}
```

1. S2 uses the value, A[i+1], computed by S1 in the same iteration.
2. S1 uses a value computed by S1 in an earlier iteration, since iteration i computes A[i+1] which is read in iteration i+1. The same is true of S2 for B[i] and B[i+1].

This is a “**loop-carried dependence**”: between iterations

For our prior example, each iteration was distinct

Implies that iterations can't be executed in parallel, Right????

# Does a loop-carried dependence mean there is no parallelism???

## Consider:

```
for (i=0; i< 8; i=i+1) {  
    A = A + C[i]; /* S1 */  
}
```

Could compute:

“Cycle 1”:

```
temp0 = C[0] + C[1];  
temp1 = C[2] + C[3];  
temp2 = C[4] + C[5];  
temp3 = C[6] + C[7];
```

“Cycle 2”:

```
temp4 = temp0 + temp1;  
temp5 = temp2 + temp3;
```

“Cycle 3”:

```
A = temp4 + temp5;
```

Relies on associative nature of “+”.

See “Parallelizing Complex Scans and Reductions” by Allan Fisher and Anwar Ghuloum (<http://doi.acm.org/10.1145/178243.178255>)



# What if We Can Change Instruction Set?

- ▶ **Superscalar processors decide on the fly how many instructions to issue**
  - ▶ HW complexity of Number of instructions to issue  $O(n^2)$
- ▶ **Why not allow compiler to schedule instruction level parallelism explicitly?**
- ▶ **Format the instructions in a potential issue packet so that HW need not check explicitly for dependences**

# VLIW: Very Large Instruction Word

➤ Each “instruction” has explicit coding for multiple operations

- In IA-64, grouping called a “packet”
- In Transmeta, grouping called a “molecule” (with “atoms” as ops)

➤ Tradeoff instruction space for simple decoding

- The long instruction word has room for many operations
- By definition, all the operations the compiler puts in the long instruction word are independent => execute in parallel
- E.g., 2 integer operations, 2 FP ops, 2 Memory refs, 1 branch
  - 16 to 24 bits per field => 7\*16 or 112 bits to 7\*24 or 168 bits wide
- Need compiling technique that schedules across several branches

# Recall: Unrolled Loop that Minimizes Stalls for Scalar

```
1 Loop: L.D    F0,0(R1)
2      L.D    F6,-8(R1)
3      L.D    F10,-16(R1)
4      L.D    F14,-24(R1)
5      ADD.D  F4,F0,F2
6      ADD.D  F8,F6,F2
7      ADD.D  F12,F10,F2
8      ADD.D  F16,F14,F2
9      S.D    0(R1),F4
10     S.D    -8(R1),F8
11     S.D    -16(R1),F12
12     DSUBUI R1,R1,#32
13     BNEZ   R1,LOOP
14     S.D    8(R1),F16 ; 8-32 = -24
```

L.D to ADD.D: 1 Cycle  
ADD.D to S.D: 2 Cycles

**14 clock cycles, or 3.5 per iteration**

# Loop Unrolling in VLIW

<i>Memory reference 1</i>	<i>Memory reference 2</i>	<i>FP operation 1</i>	<i>FP op. 2</i>	<i>Int. op/branch</i>	<i>Clock</i>
L.D F0,0(R1)	L.D F6,-8(R1)				1
L.D F10,-16(R1)	L.D F14,-24(R1)				2
L.D F18,-32(R1)	L.D F22,-40(R1)	ADD.D F4,F0,F2	ADD.D F8,F6,F2		3
L.D F26,-48(R1)		ADD.D F12,F10,F2	ADD.D F16,F14,F2		4
		ADD.D F20,F18,F2	ADD.D F24,F22,F2		5
S.D 0(R1),F4	S.D -8(R1),F8	ADD.D F28,F26,F2			6
S.D -16(R1),F12	S.D -24(R1),F16				7
S.D -32(R1),F20	S.D -40(R1),F24			DSUBUI R1,R1,#48	8
S.D -0(R1),F28				BNEZ R1,LOOP	9

**Unrolled 7 times to avoid delays**

**7 results in 9 clocks, or 1.3 clocks per iteration (1.8X)**

**Average: 2.5 ops per clock, 50% efficiency**

**Note: Need more registers in VLIW (15 vs. 6 in SS)**

# Software Pipelining

- ▶ **Observation:** if iterations from loops are independent, then can get more ILP by taking instructions from different iterations
- ▶ **Software pipelining:** reorganizes loops so that each iteration is made from instructions chosen from different iterations of the original loop (~ Tomasulo in SW)

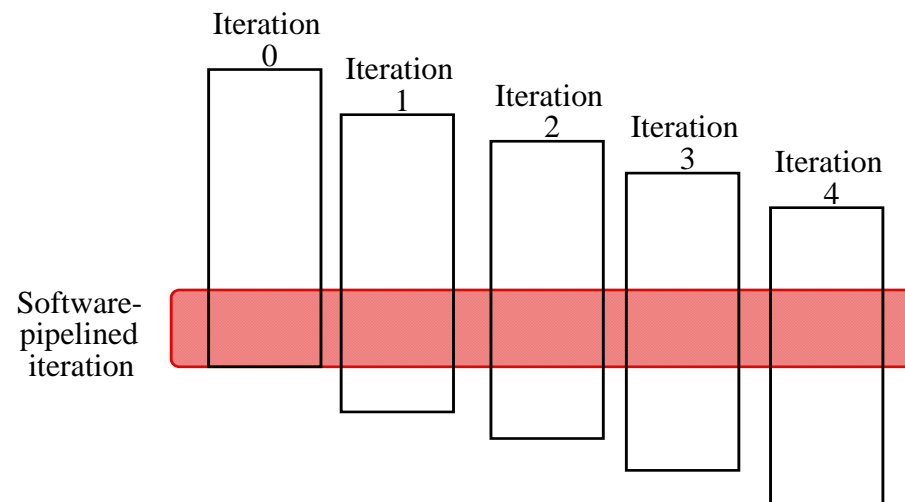

# Software Pipelining Example

Before: Unrolled 3 times

```

1  L.D    F0,0(R1)
2  ADD.D  F4,F0,F2
3  S.D    0(R1),F4
4  L.D    F6,-8(R1)
5  ADD.D  F8,F6,F2
6  S.D    -8(R1),F8
7  L.D    F10,-16(R1)
8  ADD.D  F12,F10,F2
9  S.D    -16(R1),F12
10 DSUBUI R1,R1,#24
11 BNEZ   R1,LOOP
    
```

After: Software Pipelined

```

1  S.D    0(R1),F4 ; Stores M[i]
2  ADD.D  F4,F0,F2 ; Adds to M[i-1]
3  L.D    F0,-16(R1); Loads M[i-2]
4  DSUBUI R1,R1,#8
5  BNEZ   R1,LOOP
    
```

- **Symbolic Loop Unrolling**

- Maximize result-use distance
- Less code space than unrolling
- Fill & drain pipe only once per loop  
vs. once per each unrolled iteration in loop unrolling

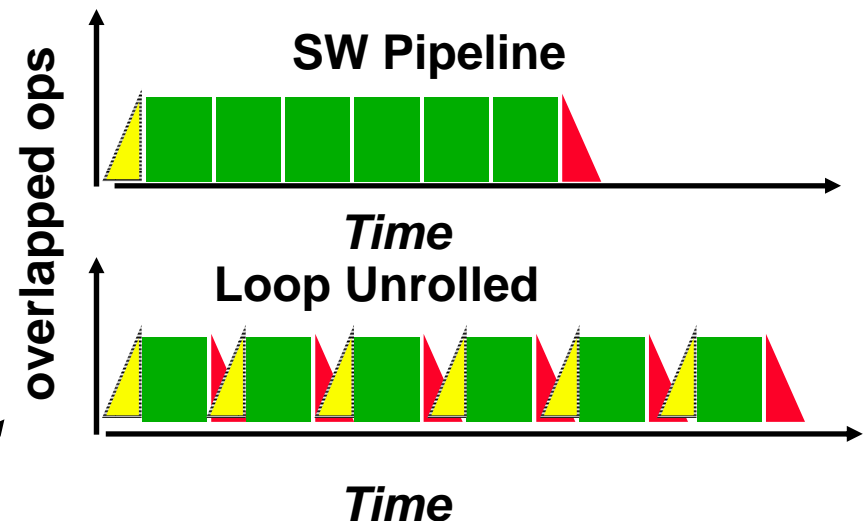

# Software Pipelining with Loop Unrolling in VLIW

<i>Memory reference 1</i>	<i>Memory reference 2</i>	<i>FP operation 1</i>	<i>FP operation 2</i>	<i>Int. op/ branch</i>	<i>Clock</i>
L.D F0,-48(R1)	ST 0(R1),F4	ADD.D F4,F0,F2			1
L.D F6,-56(R1)	ST -8(R1),F8	ADD.D F8,F6,F2		DSUBUI R1,R1,#24	2
L.D F10,-40(R1)	ST 8(R1),F12	ADD.D F12,F10,F2		BNEZ R1,LOOP	3

## Software pipelined across 9 iterations of original loop

➔ In each iteration of above loop, we:

- Store to m,m-8,m-16 (iterations l-3,l-2,l-1)
- Compute for m-24,m-32,m-40 (iterations l,l+1,l+2)
- Load from m-48,m-56,m-64 (iterations l+3,l+4,l+5)

➔ 9 results in 9 cycles, or 1 clock per iteration

➔ Average: 3.3 ops per clock, 66% efficiency

**Note: Need fewer registers for software pipelining (only using 7 registers here, was using 15)**

# Trace Scheduling

Parallelism across IF branches vs. LOOP branches?

Two steps:

➤ **Trace Selection**

- Find likely sequence of basic blocks (*trace*) of (statically predicted or profile predicted) long sequence of straight-line code

➤ **Trace Compaction**

- Squeeze trace into few VLIW instructions
- Need bookkeeping code in case prediction is wrong

This is a form of compiler-generated speculation

- Compiler must generate “fixup” code to handle cases in which trace is not the taken branch
- Needs extra registers: undoes bad guess by discarding

Subtle compiler bugs mean wrong answer vs. poorer performance; no hardware interlocks

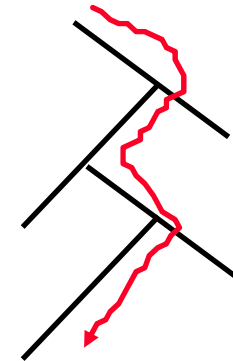

# Advantages of HW (Tomasulo) vs. SW (VLIW) Speculation

## HW advantages:

- HW better at memory disambiguation since knows actual addresses
- HW better at branch prediction since lower overhead
- HW maintains precise exception model
- HW does not execute bookkeeping instructions
- Same software works across multiple implementations
- Smaller code size (not as many nops filling blank instructions)

## SW advantages:

- Window of instructions that is examined for parallelism much higher
- Much less hardware involved in VLIW (unless you are Intel...!)
- More involved types of speculation can be done more easily
- Speculation can be based on large-scale program behavior, not just local information

# Superscalar v. VLIW

- ▶ **Smaller code size**
- ▶ **Binary compatibility across generations of hardware**
- ▶ **Simplified Hardware for decoding, issuing instructions**
- ▶ **No Interlock Hardware (compiler checks?)**
- ▶ **More registers, but simplified Hardware for Register Ports (multiple independent register files?)**

# Real VLIW

## VLIW Minisupercomputers/Superminicomputers:

- ▶ Multiflow TRACE 7/300, 14/300, 28/300 [Josh Fisher]
- ▶ Multiflow TRACE /500 [Bob Colwell]
- ▶ Cydrome Cydra 5 [Bob Rau]
- ▶ IBM Yorktown VLIW Computer (research machine)

## Single-Chip VLIW Processors:

- ▶ Intel iWarp

## Single-Chip VLIW Media (throughput) Processors:

- ▶ Trimedia, Chromatic, Micro-Unity
- ▶ DSP Processors (TI TMS320C6x )

## Hybrids...

- ▶ Intel/HP EPIC IA-64 (Explicitly Parallel Instruction Comp.)
- ▶ Transmeta Crusoe (x86 on VLIW??)

# Problems with First Generation VLIW

## ➤ Increase in code size

- generating enough operations in a straight-line code fragment requires ambitiously unrolling loops
- whenever VLIW instructions are not full, unused functional units translate to wasted bits in instruction encoding

## ➤ Operated in lock-step; no hazard detection HW

- a stall in any functional unit pipeline caused entire processor to stall, since all functional units must be kept synchronized
- Compiler might know functional unit latencies, but caches harder to predict

## ➤ Binary code compatibility

- Pure VLIW => different numbers of functional units and unit latencies require different versions of the code

# Intel/HP IA-64 “Explicitly Parallel Instruction Computer (EPIC)”

## ▶ IA-64: instruction set architecture; EPIC is type

- ▶ EPIC = 2nd generation VLIW?

## ▶ Itanium™ first implementation

- ▶ Highly parallel and deeply pipelined hardware at 800Mhz
- ▶ 6-wide, 10-stage pipeline
- ▶ Not competitive

## ▶ Itanium 2

- ▶ 6-wide, 8-stage pipeline
- ▶ 16KB L1I, 16KB L1D (one cycle), 256KB L2 (5 cycle), 3MB L3 (12 cycle), all on-die
- ▶ <http://www.intel.com/products/server/processors/server/itanium2/>
- ▶ Competitive for some applications (eg SPEC FP)

## ▶ 128 64-bit integer registers + 128 82-bit floating point registers

- ▶ Not separate register files per functional unit as in old VLIW

## ▶ Hardware checks dependencies (interlocks => binary compatibility over time)

## ▶ Predicated execution (select 1 out of 64 1-bit flags) => 40% fewer mispredictions?

# Hardware Support for Exposing More Parallelism at Compile-Time

To help trace scheduling and software pipelining, the Itanium instruction set includes several interesting mechanisms:

- ▀ Predicated execution
- ▀ Speculative, non-faulting Load instruction
- ▀ Software-assisted branch prediction
- ▀ Register stack
- ▀ Rotating register frame
- ▀ Software-assisted memory hierarchy

▀ **Job creation scheme for compiler engineers**

# IA64: Speculative, Non-Faulting Load

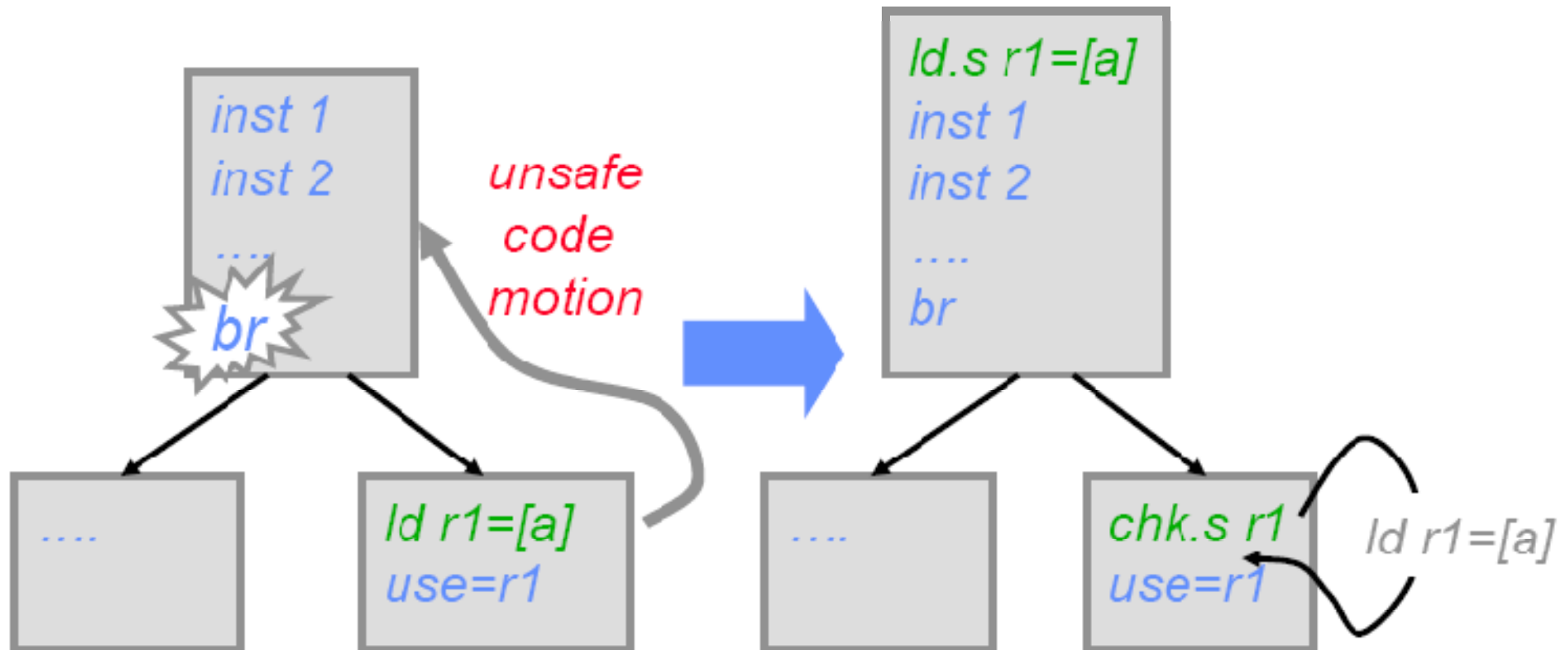

- `ld.s` fetches speculatively from memory
  - i.e. any exception due to `ld.s` is suppressed
- If `ld.s r` did not cause an exception then `chk.s r` is an NOP, else a branch is taken to some compensation code

# IA64: Speculative, Non-Faulting Load

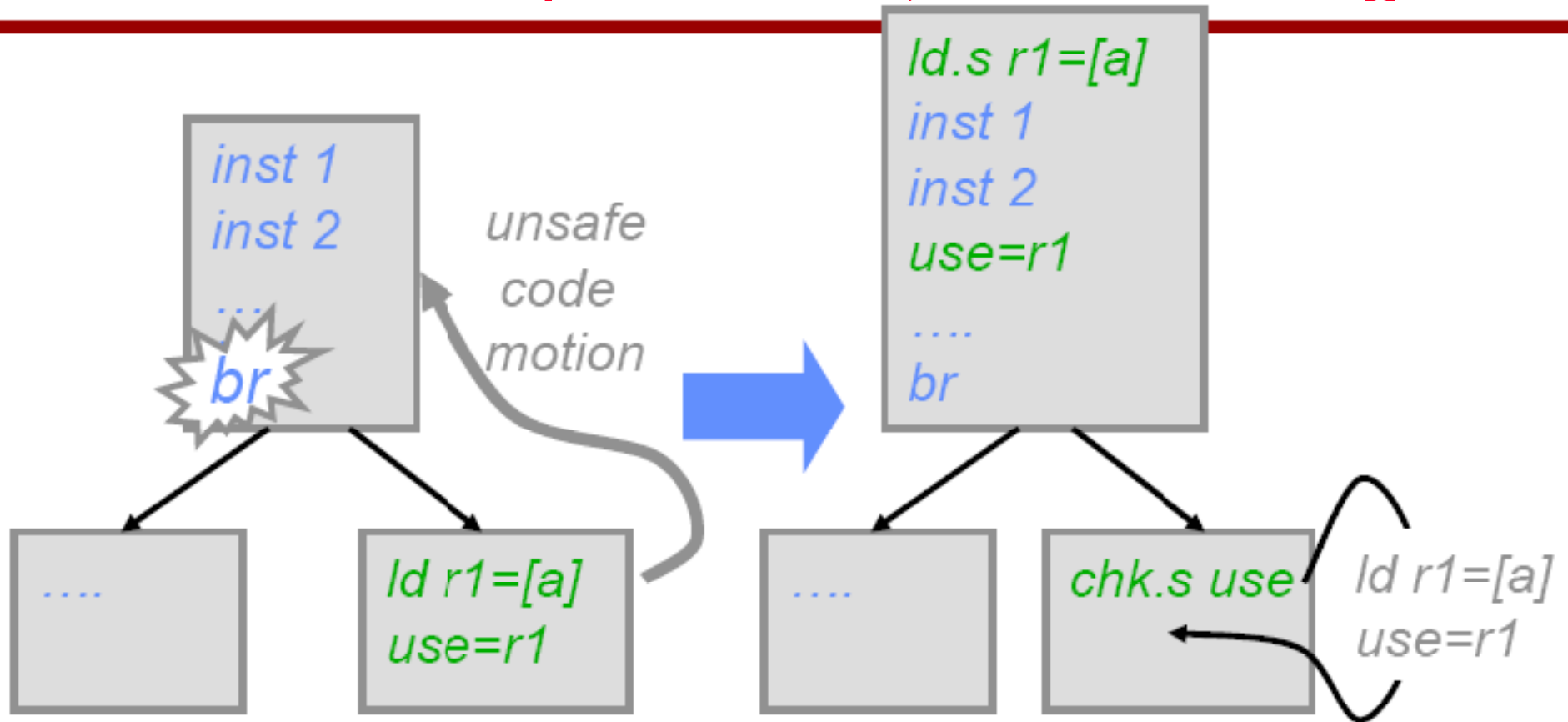

- ▀ Speculatively-loaded data can be consumed prior to check
- ▀ “speculation” status is propagated with speculated data
- ▀ Any instruction that uses a speculative result also becomes  
    ➔ (i.e. suppressed exceptions)
- ▀ **chk.s** checks the entire dataflow sequence for exceptions

# IA64: Speculative “Advanced” Load

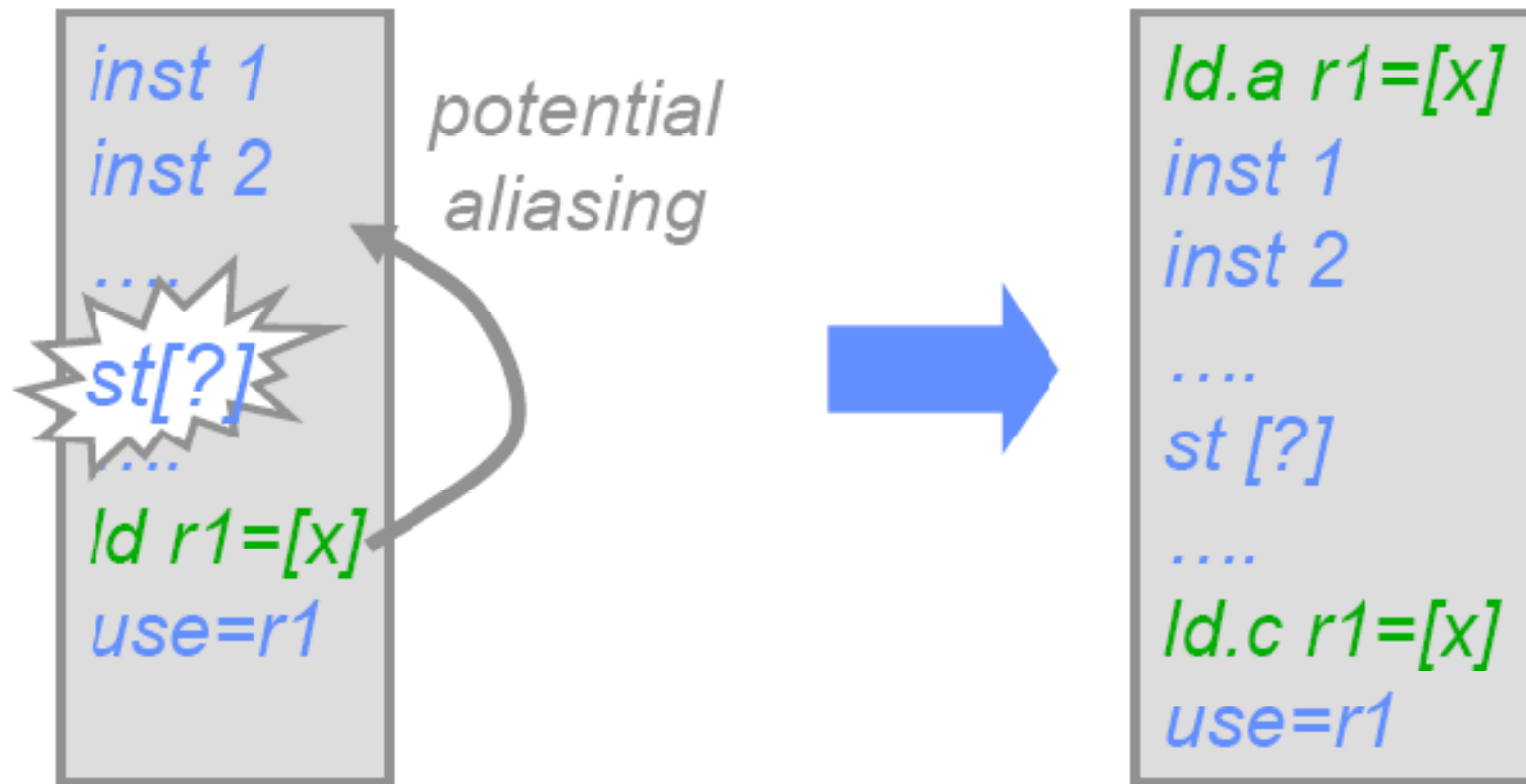

- ▶ **ld.a** starts the monitoring of any store to the same address as the advanced load
- ▶ If no aliasing has occurred since **ld.a**, **ld.c** is a NOP
- ▶ If aliasing has occurred, **ld.c** re-loads from memory

# IA64: Branch prediction

## ▶ Static branch hints can be encoded with every branch

- ▶ taken vs. not-taken
- ▶ whether to allocate an entry in the dynamic BP hardware

## ▶ SW and HW has joint control of BP hardware

- ▶ “brp” (branch prediction) instruction can be issued ahead of the actual branch to preset the contents of BHT and TBT

Itanium-1 used a 512-entry 2-level BHT and 64-entry BTB

## ▶ TAR (Target Address Register)

- ▶ a small, fully-associative BTAC-like structure
- ▶ contents are controlled entirely by a “prepare-to-branch” inst.
- ▶ a hit in TAR overrides all other predictions

## ▶ RSB (Return Address Stack)

- ▶ Procedure return addr is pushed (or popped) when a procedure is called (or when it returns)
- ▶ Predicts nPC when executing register-indirect branches

# IA64: Software-Assisted Memory Hierarchies

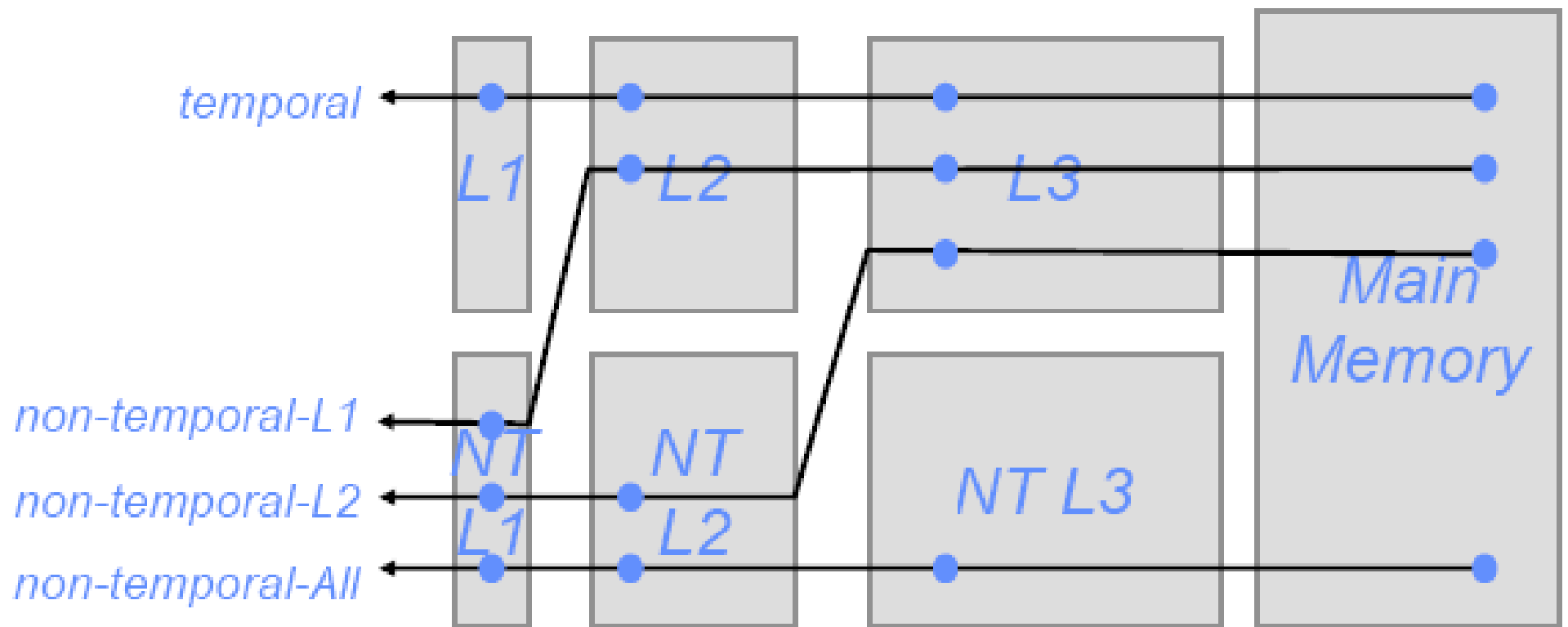

- ISA provides for separate storages for “temporal” vs “non-temporal” data, each with its own multiple level of hierarchies
- Load and Store instructions can give hints about where cached copies should be held after a cache miss

# IA-64 Registers

▶ **The integer registers are configured to help accelerate procedure calls using a register stack**

- ▶ mechanism similar to that developed in the Berkeley RISC-I processor and used in the SPARC architecture.
- ▶ Registers 0-31 are always accessible and addressed as 0-31
- ▶ Registers 32-128 are used as a register stack and each procedure is allocated a set of registers (from 0 to 96)
- ▶ The new register stack frame is created for a called procedure by renaming the registers in hardware;
- ▶ a special register called the current frame pointer (CFM) points to the set of registers to be used by a given procedure

▶ **8 64-bit Branch registers used to hold branch destination addresses for indirect branches**

▶ **64 1-bit predicate registers**

# Intel/HP IA-64 “Explicitly Parallel Instruction Computer (EPIC)”

▶ **Instruction group**: a sequence of consecutive instructions with no register data dependences

- ▶ All the instructions in a group could be executed in parallel, if sufficient hardware resources existed and if any dependences through memory were preserved
- ▶ An instruction group can be arbitrarily long, but the compiler must explicitly indicate the boundary between one instruction group and another by placing a **stop** between 2 instructions that belong to different groups

▶ IA-64 instructions are encoded in **bundles**, which are 128 bits wide.

- ▶ Each bundle consists of a 5-bit template field and 3 instructions, each 41 bits in length

▶ 3 Instructions in 128 bit “groups”; field determines if instructions dependent or independent

- ▶ Smaller code size than old VLIW, larger than x86/RISC
- ▶ Groups can be linked to show independence > 3 instr

# 5 Types of Execution in Bundle

<b><i>Execution Unit Slot</i></b>	<b><i>Instruction type</i></b>	<b><i>Instruction Description</i></b>	<b><i>Example Instructions</i></b>
<b>I-unit</b>	<b>A</b>	<b>Integer ALU</b>	<b>add, subtract, and, or, cmp</b>
	<b>I</b>	<b>Non-ALU Int</b>	<b>shifts, bit tests, moves</b>
<b>M-unit</b>	<b>A</b>	<b>Integer ALU</b>	<b>add, subtract, and, or, cmp</b>
	<b>M</b>	<b>Memory access</b>	<b>Loads, stores for int/FP regs</b>
<b>F-unit</b>	<b>F</b>	<b>Floating point</b>	<b>Floating point instructions</b>
<b>B-unit</b>	<b>B</b>	<b>Branches</b>	<b>Conditional branches, calls</b>
<b>L+X</b>	<b>L+X</b>	<b>Extended</b>	<b>Extended immediates, stops</b>

- **5-bit template field within each bundle describes both the presence of any stops associated with the bundle *and* the execution unit type required by each instruction within the bundle (see Fig 4.12 page 271)**

# IA-64 Registers

- ▶ **Both the integer and floating point registers support register rotation for registers 32-128.**
- ▶ **Register rotation is designed to ease the task of register allocation in software pipelined loops**
- ▶ **When combined with predication, possible to avoid the need for unrolling and for separate prologue and epilogue code for a software pipelined loop**
  - ▶ **makes the SW-pipelining usable for loops with smaller numbers of iterations, where the overheads would traditionally negate many of the advantages**

# How Register Rotation Helps Software Pipelining

The concept of a software pipelining branch:

```
L1:    ld4      r35 = [r4], 4    // post-increment by 4
       st4      [r5] = r37, 4    // post-increment by 4
       br.ctop L1 ;;
```

The `br.ctop` instruction in the example rotates the general registers (actually `br.ctop` does more as we shall see)

Therefore the value stored into `r35` is read in `r37` two iterations (and two rotations) later.

The register rotation eliminated a dependence between the load and the store instructions, and allowed the loop to execute in one cycle.

- ▶ Register rotation is useful for procedure calls
- ▶ It's also useful for software-pipelined loops
- ▶ The logical-to-physical register mapping is shifted by 1 each time the branch (“`br.ctop`”) is executed

# Software Pipelining Example in the IA-64

```
mov pr.rot      = 0    // Clear all rotating predicate registers
cmp.eq p16,p0 = r0,r0 // Set p16=1
mov ar.lc       = 4    // Set loop counter to n-1
mov ar.ec       = 3    // Set epilog counter to 3
...
loop:
(p16) ldl r32 = [r12], 1 // Stage 1: load x
(p17) add r34 = 1, r33   // Stage 2: y=x+1
(p18) stl [r13] = r35,1 // Stage 3: store y
      br.ctop loop      // Branch back
```

- ▶ “Stage” predicate mechanism allows successive stages of the software pipeline to be filled on start-up and drained when the loop terminates
- ▶ The software pipeline branch “br.ctop” rotates the predicate registers, and injects a 1 into p16
- ▶ Thus enabling one stage at a time, for execution of prologue
- ▶ When loop trip count is reached, “br.ctop” injects 0 into p16, disabling one stage at a time, then finally falls-through

# Software Pipelining Example in the IA-64

```

loop:
(p16)  ldl r32  = [r12], 1
(p17)  add r34  = 1, r33
(p18)  stl [r13] = r35, 1
      br.ctop loop
    
```

General Registers (Physical)

32 33 34 35 36 37 38 39

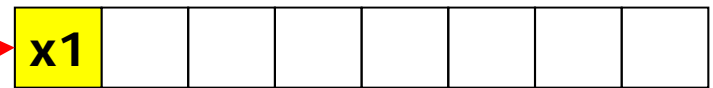

32 33 34 35 36 37 38 39

General Registers (Logical)

Predicate Registers



16 17 18

LC



EC



RRB



Memory

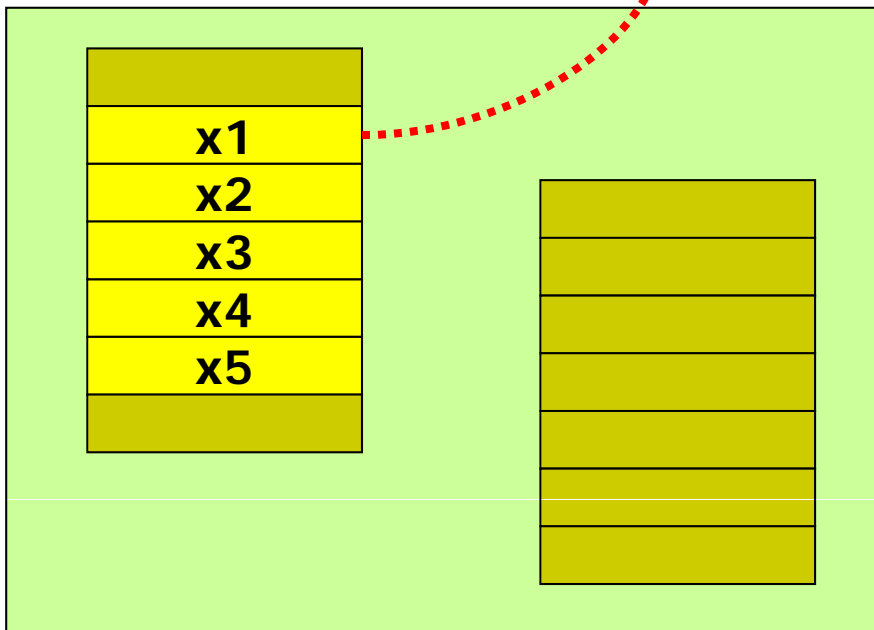

# Software Pipelining Example in the IA-64

```
loop:  
(p16) ldl r32 = [r12], 1  
(p17) add r34 = 1, r33  
(p18) stl [r13] = r35, 1  
br.ctop loop
```



Memory

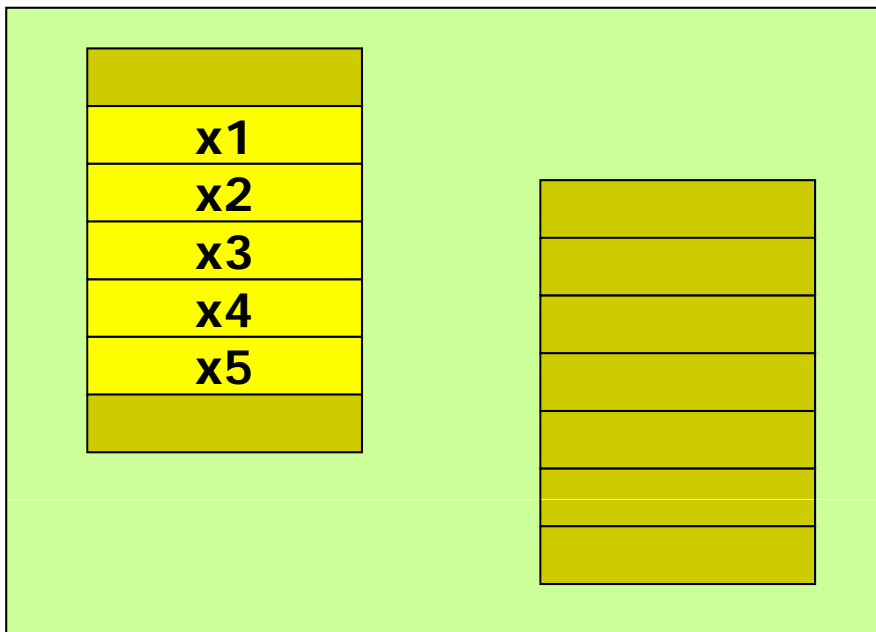

General Registers (Physical)

32 33 34 35 36 37 38 39

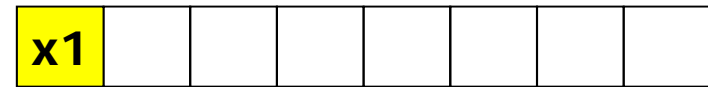

32 33 34 35 36 37 38 39  
General Registers (Logical)

Predicate Registers



16 17 18

LC



EC



RRB



# Software Pipelining Example in the IA-64

```
loop:  
(p16) ldl r32 = [r12], 1  
(p17) add r34 = 1, r33  
(p18) stl [r13] = r35, 1  
br.ctop loop
```



Memory

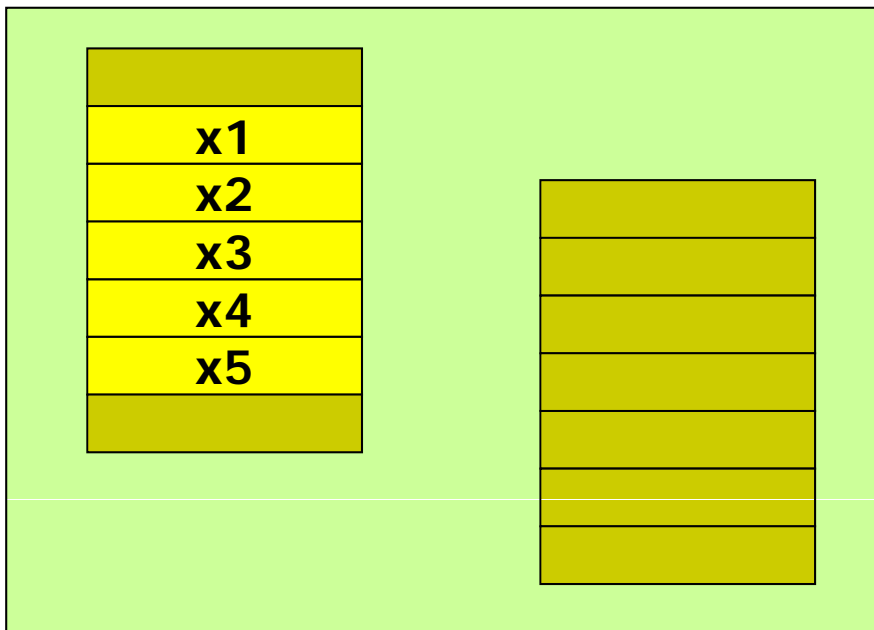

General Registers (Physical)

32 33 34 35 36 37 38 39

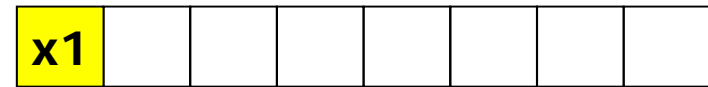

32 33 34 35 36 37 38 39  
General Registers (Logical)

Predicate Registers



16 17 18

LC



EC



RRB



# Software Pipelining Example in the IA-64

```

loop:
(p16)  ldl r32  = [r12], 1
(p17)  add r34  = 1, r33
(p18)  stl [r13] = r35,1
      br.ctop loop
    
```



Memory

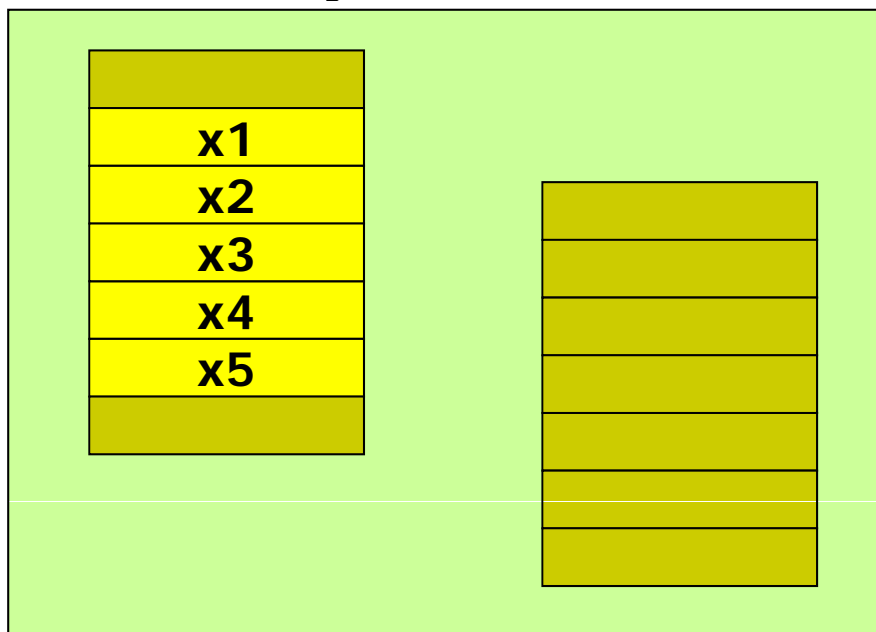

General Registers (Physical)

32 33 34 35 36 37 38 39

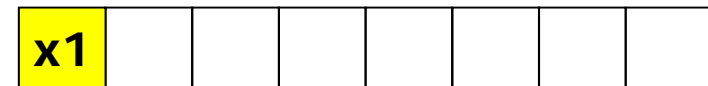

33 34 35 36 37 38 39 32  
General Registers (Logical)

Predicate Registers

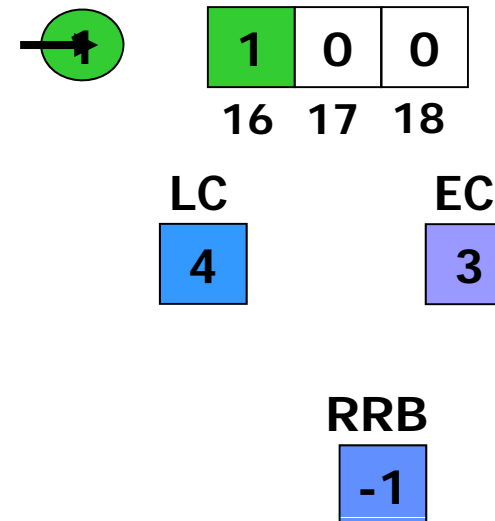

# Software Pipelining Example in the IA-64

```

loop:
(p16)  ldl r32  = [r12], 1
(p17)  add r34  = 1, r33
(p18)  stl [r13] = r35,1
      br.ctop loop
    
```



Memory

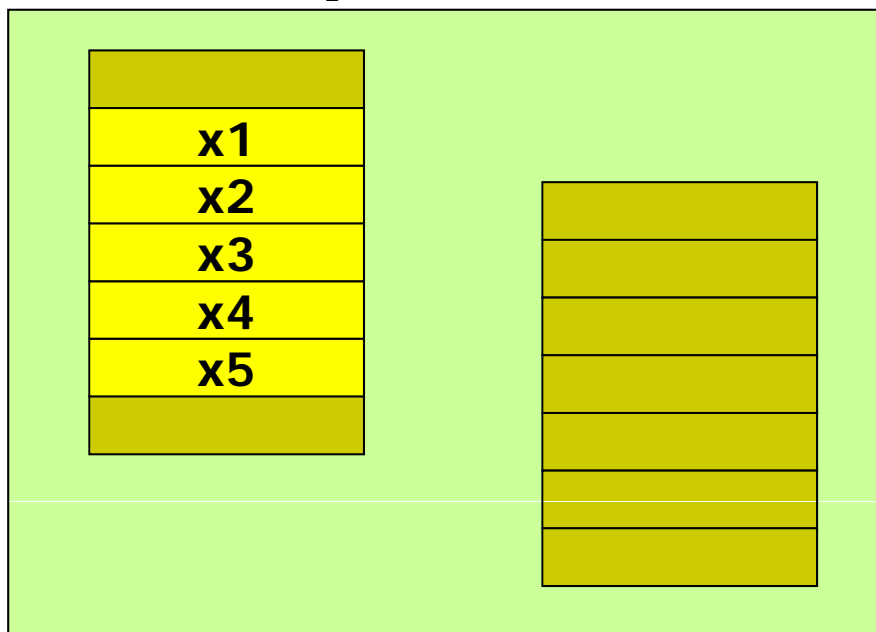

General Registers (Physical)

32 33 34 35 36 37 38 39

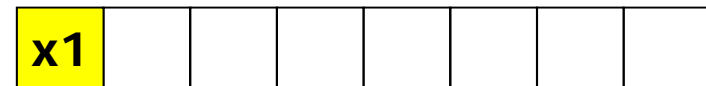

General Registers (Logical)

Predicate Registers



16 17 18

LC



EC



RRB



# Software Pipelining Example in the IA-64

```

loop:
(p16)  ldl r32  = [r12], 1
(p17)  add r34  = 1, r33
(p18)  stl [r13] = r35, 1
      br.ctop loop
    
```

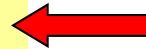

General Registers (Physical)

32 33 34 35 36 37 38 39

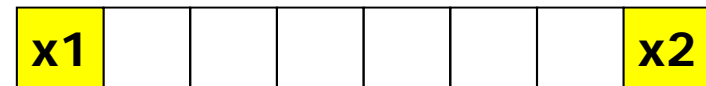

33 34 35 36 37 38 39 32  
General Registers (Logical)

Predicate Registers

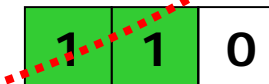

16 17 18

LC

3

EC

3

RRB

-1

Memory

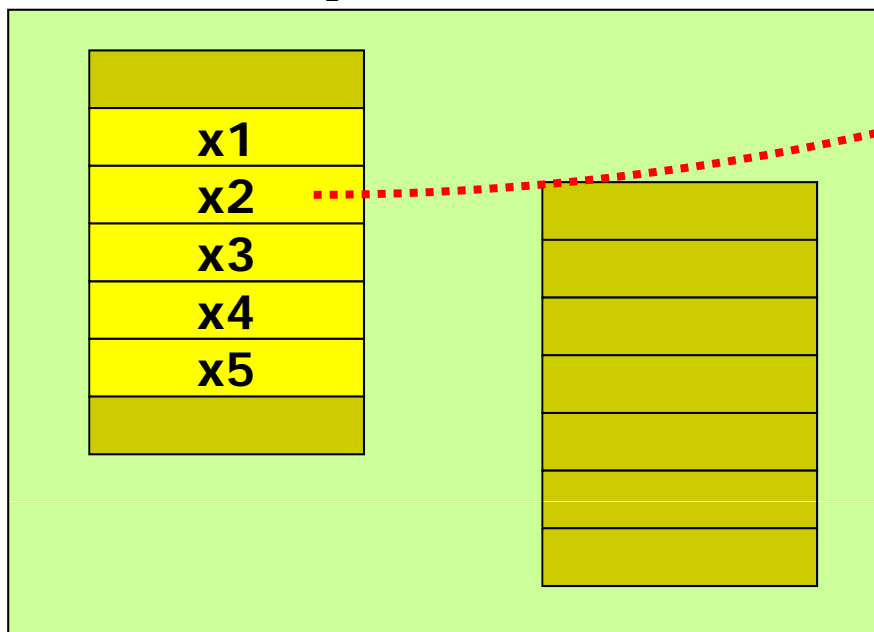

# Software Pipelining Example in the IA-64

```

loop:
(p16)  ldl r32  = [r12], 1
(p17)  add r34  = 1, r33
(p18)  stl [r13] = r35,1
      br.ctop loop
    
```



Memory

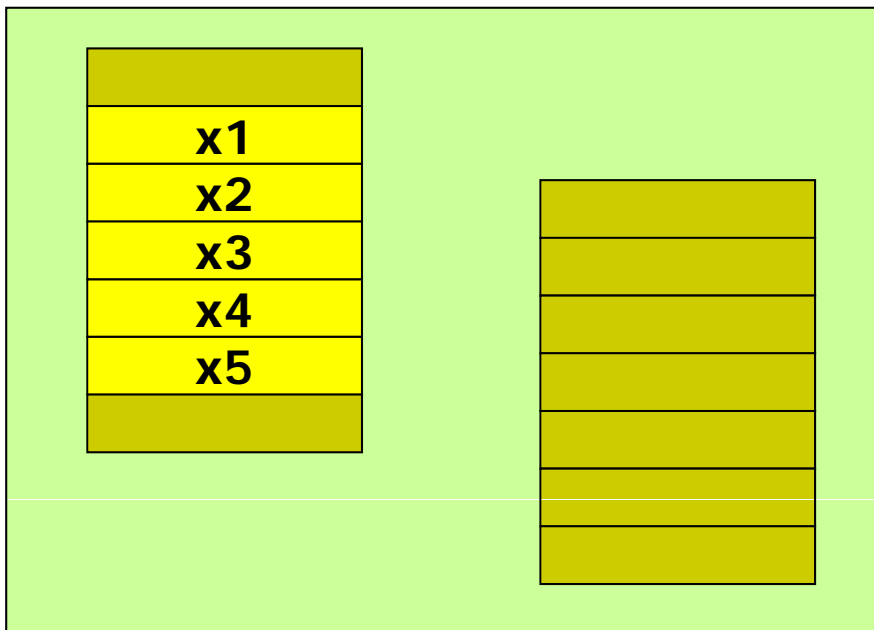

General Registers (Physical)

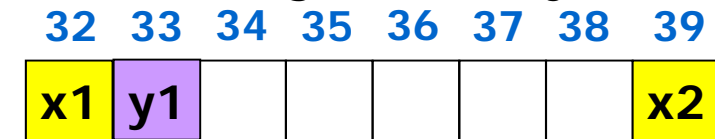

General Registers (Logical)

Predicate Registers

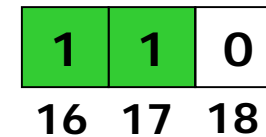

LC



EC



RRB



# Software Pipelining Example in the IA-64

```

loop:
(p16)  ldl r32  = [r12], 1
(p17)  add r34  = 1, r33
(p18)  stl [r13] = r35, 1
      br.ctop loop
    
```



Memory

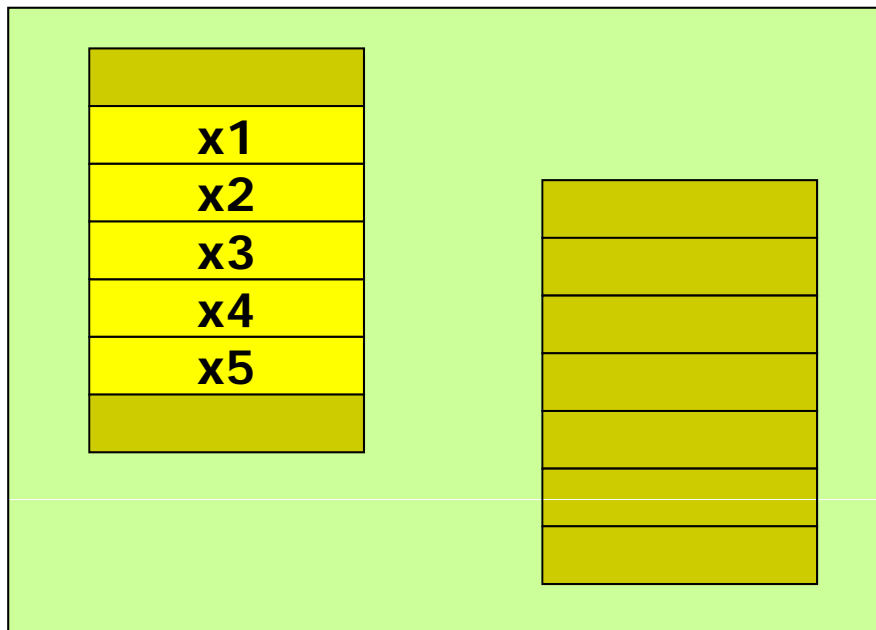

General Registers (Physical)

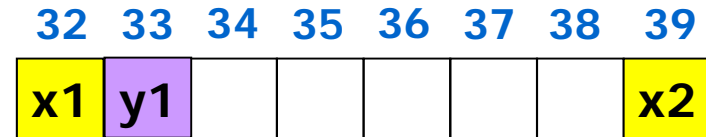

General Registers (Logical)



Predicate Registers

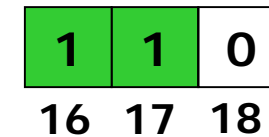

LC



EC



RRB



# Software Pipelining Example in the IA-64

```

loop:
(p16)  ldl r32  = [r12], 1
(p17)  add r34  = 1, r33
(p18)  stl [r13] = r35,1
      br.ctop loop
    
```

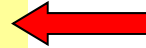

Memory

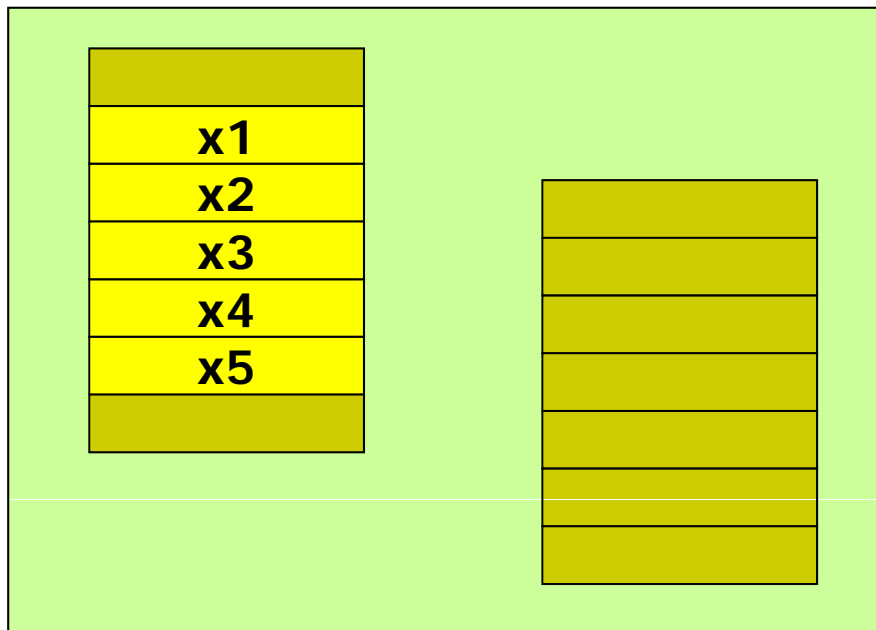

General Registers (Physical)

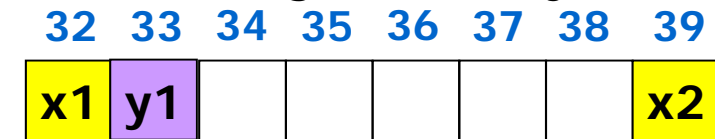

General Registers (Logical)



Predicate Registers

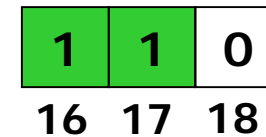

LC



EC



RRB



# Software Pipelining Example in the IA-64

```

loop:
(p16)  ldl r32  = [r12], 1
(p17)  add r34  = 1, r33
(p18)  stl [r13] = r35,1
      br.ctop loop
    
```

Memory

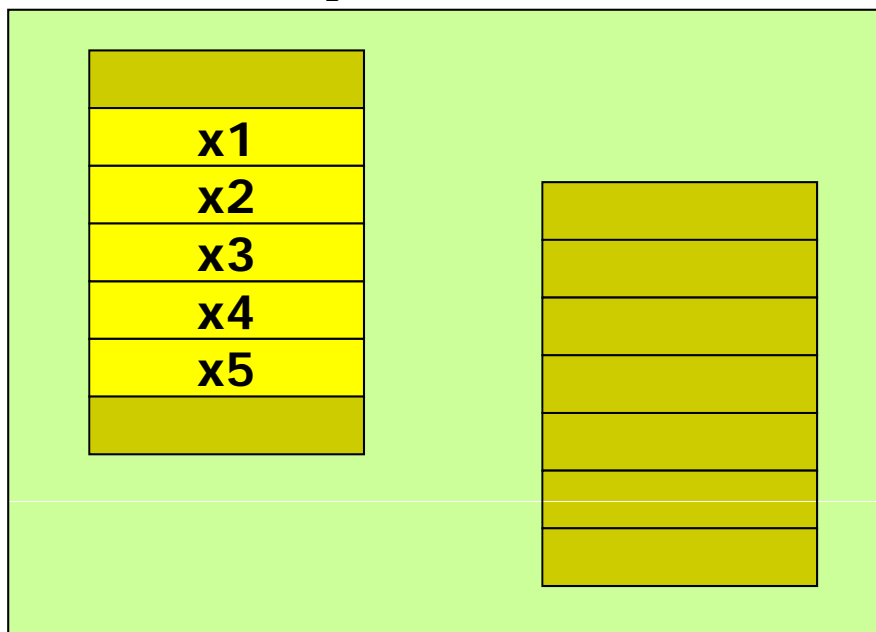

General Registers (Physical)

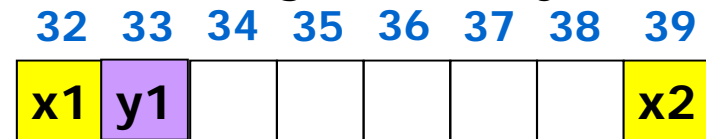

General Registers (Logical)

Predicate Registers

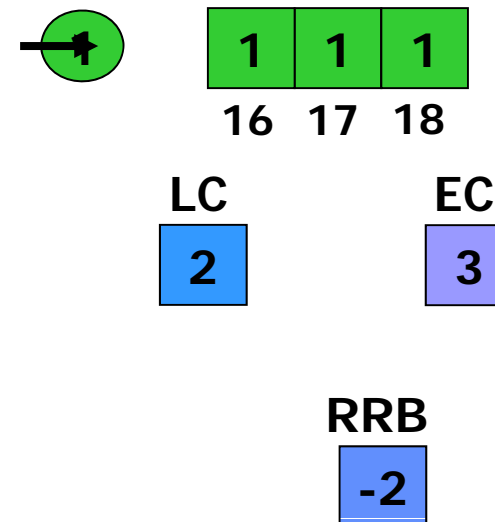

# Software Pipelining Example in the IA-64

```

loop:
(p16)  ldl r32  = [r12], 1
(p17)  add r34  = 1, r33
(p18)  stl [r13] = r35, 1
      br.ctop loop
    
```

Memory

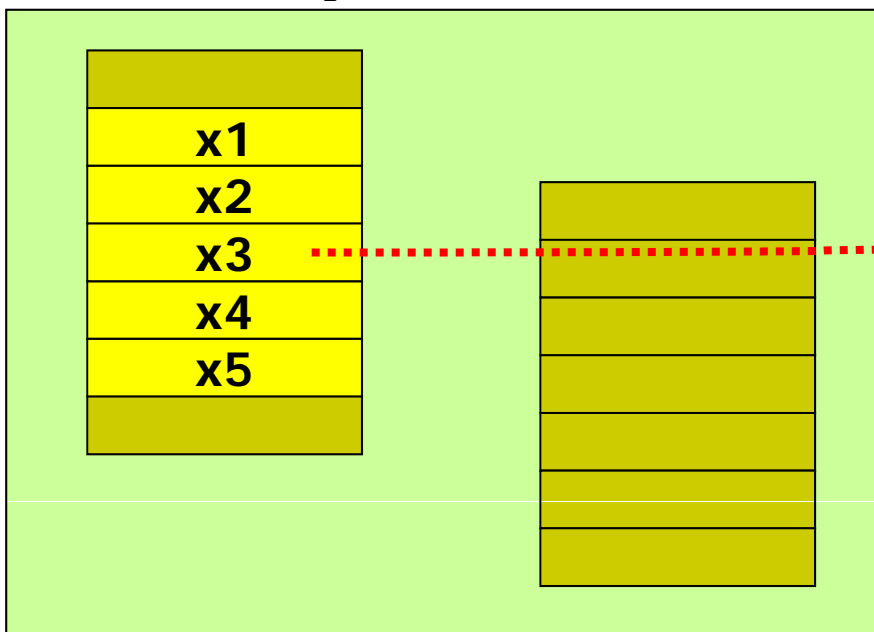

General Registers (Physical)

32 33 34 35 36 37 38 39

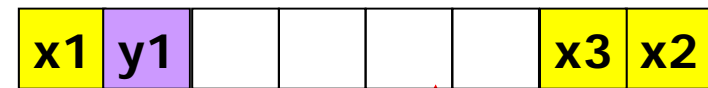

34 35 36 37 38 39 32 33  
General Registers (Logical)

Predicate Registers



16 17 18

LC



EC



RRB



# Software Pipelining Example in the IA-64

```

loop:
(p16) ldl r32 = [r12], 1
(p17) add r34 = 1, r33
(p18) stl [r13] = r35, 1
      br.ctop loop
    
```



Memory

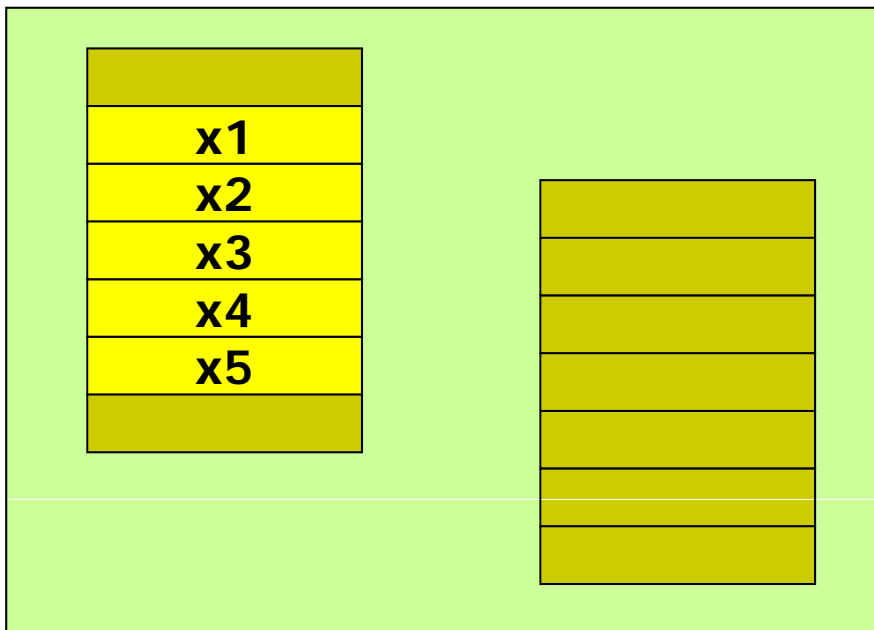

General Registers (Physical)

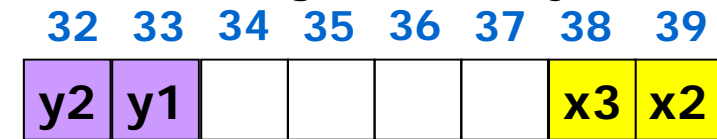

General Registers (Logical)

Predicate Registers



16 17 18

LC



EC



RRB



# Software Pipelining Example in the IA-64

```

loop:
(p16)  ldl r32  = [r12], 1
(p17)  add r34  = 1, r33
(p18)  stl [r13] = r35, 1
      br.ctop loop
    
```

Memory

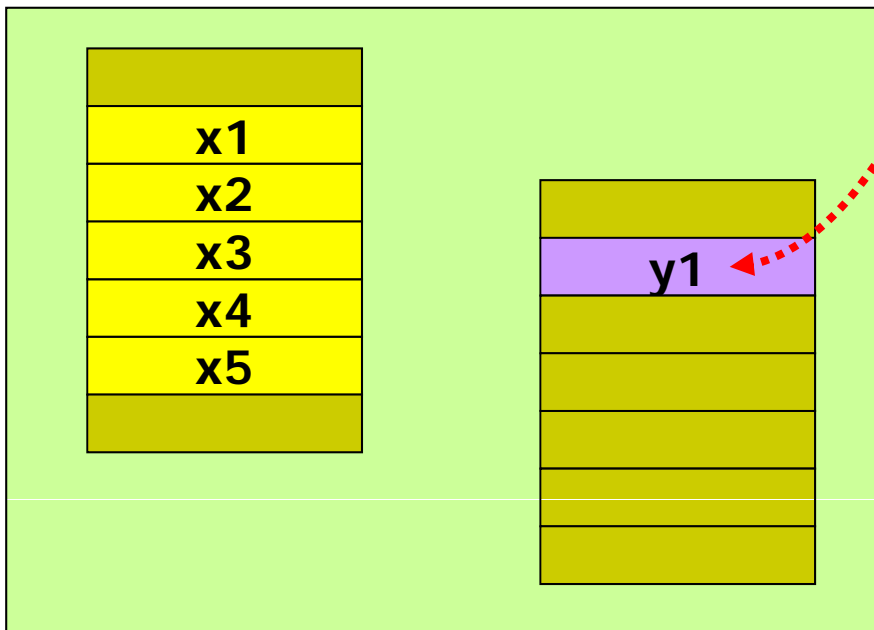

General Registers (Physical)

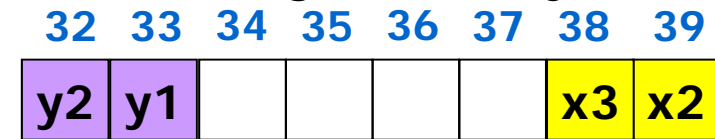

General Registers (Logical)



Predicate Registers



16 17 18

LC



EC



RRB



# Software Pipelining Example in the IA-64

```

loop:
(p16)  ldl r32  = [r12], 1
(p17)  add r34  = 1, r33
(p18)  stl [r13] = r35,1
      br.ctop loop
    
```

Memory

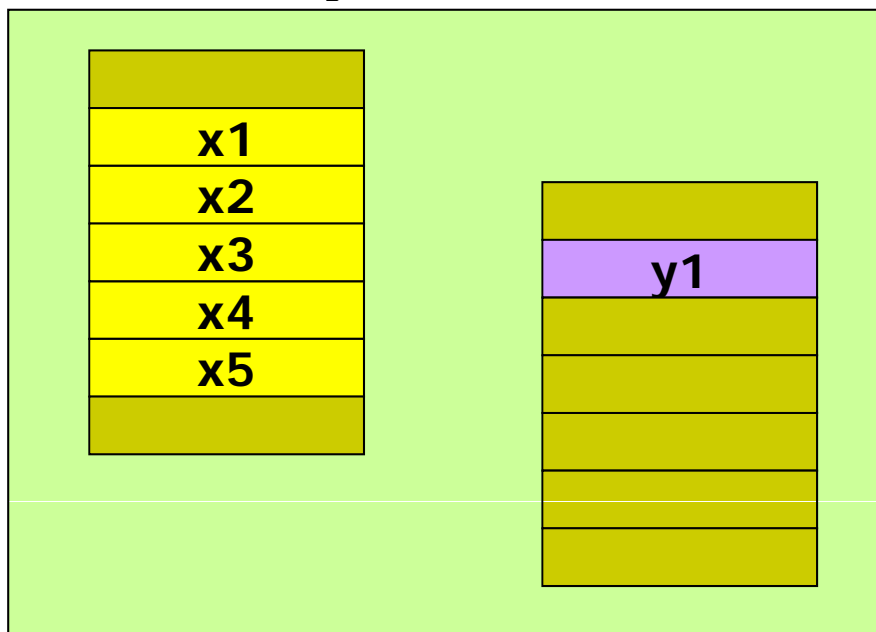

General Registers (Physical)

32 33 34 35 36 37 38 39

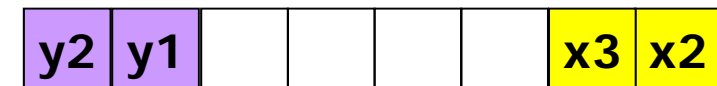

34 35 36 37 38 39 32 33

General Registers (Logical)

Predicate Registers

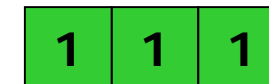

16 17 18

LC



EC



RRB



# Software Pipelining Example in the IA-64

```

loop:
(p16)  ldl r32  = [r12], 1
(p17)  add r34  = 1, r33
(p18)  stl [r13] = r35,1
      br.ctop loop
    
```

Memory

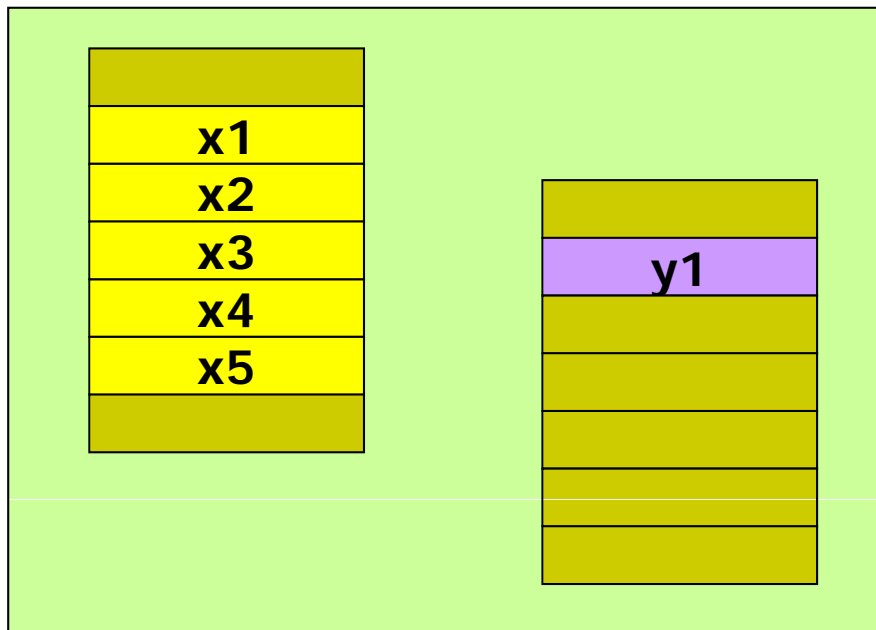

General Registers (Physical)

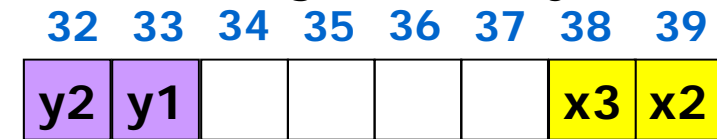

General Registers (Logical)

Predicate Registers

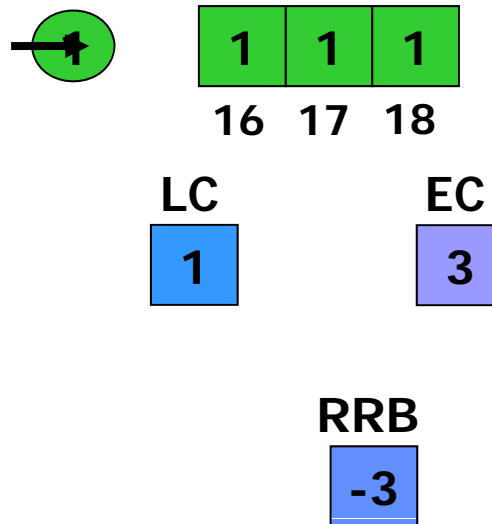

# Software Pipelining Example in the IA-64

```

loop:
(p16)  ldl r32  = [r12], 1
(p17)  add r34  = 1, r33
(p18)  stl [r13] = r35, 1
      br.ctop loop
    
```

General Registers (Physical)

32 33 34 35 36 37 38 39

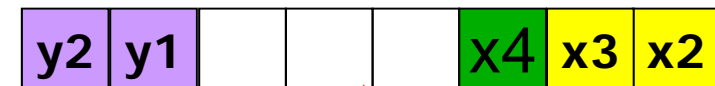

35 36 37 38 39 32 33 34

General Registers (Logical)

Predicate Registers

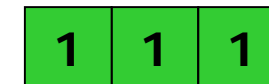

16 17 18

LC



EC



RRB



Memory

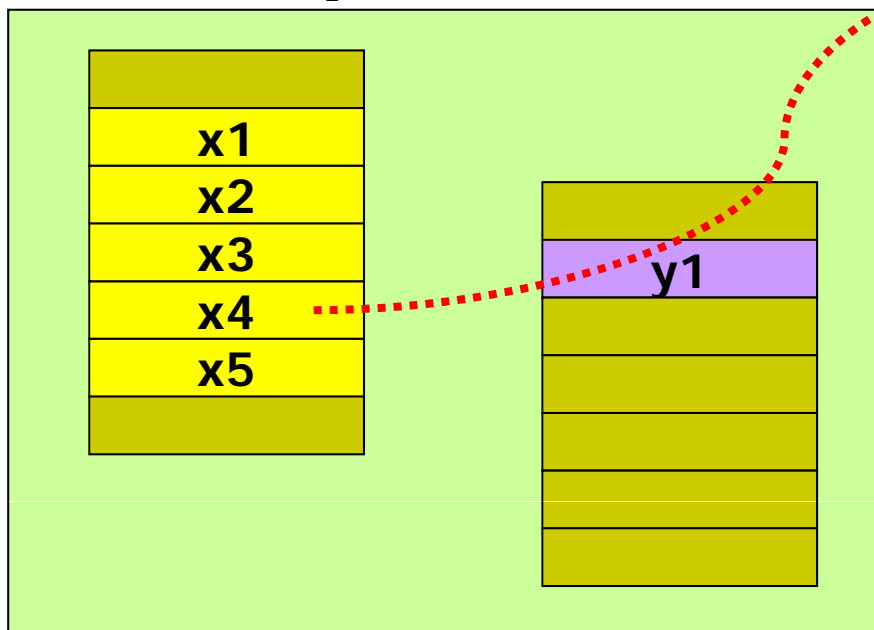

# Software Pipelining Example in the IA-64

```

loop:
(p16) ldl r32 = [r12], 1
(p17) add r34 = 1, r33
(p18) stl [r13] = r35, 1
      br.ctop loop
    
```



Memory

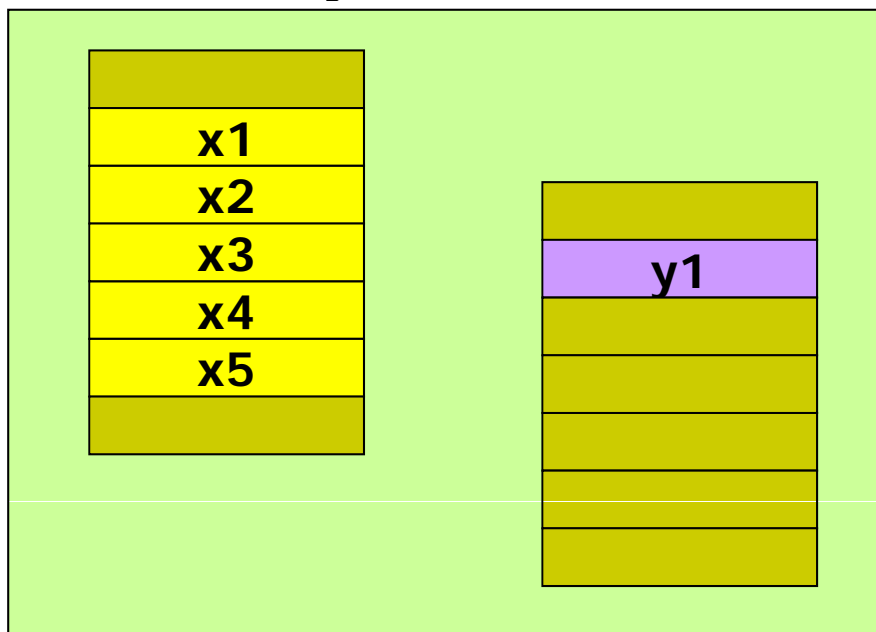

General Registers (Physical)

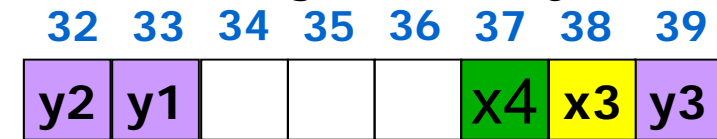

General Registers (Logical)

Predicate Registers

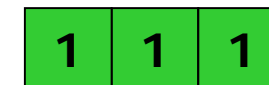

16 17 18

LC



EC



RRB



# Software Pipelining Example in the IA-64

```

loop:
(p16) ldl r32 = [r12], 1
(p17) add r34 = 1, r33
(p18) stl [r13] = r35, 1
      br.ctop loop
    
```

Memory

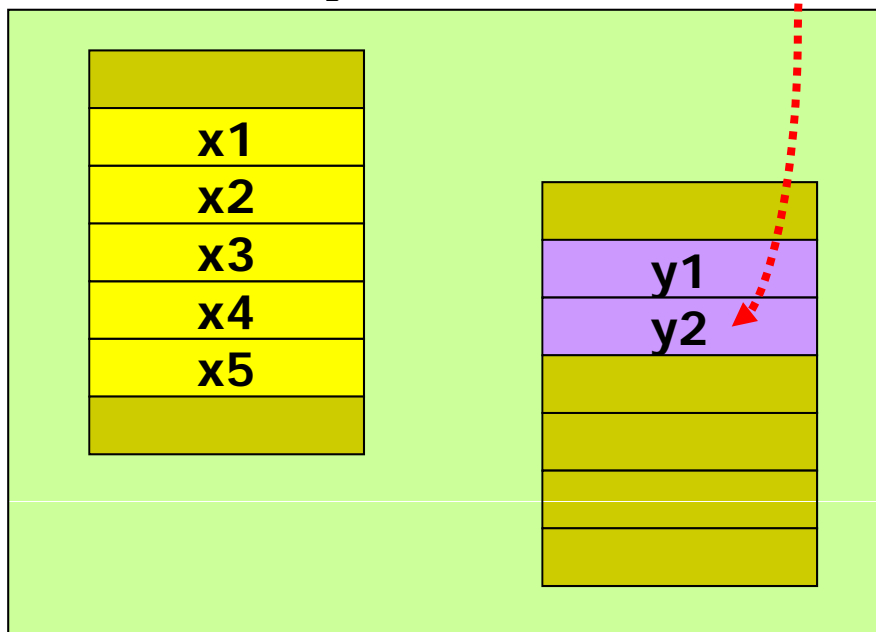

General Registers (Physical)

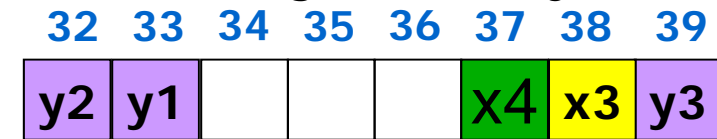

General Registers (Logical)



Predicate Registers



16 17 18

LC



EC



RRB



# Software Pipelining Example in the IA-64

```

loop:
(p16)  ldl r32  = [r12], 1
(p17)  add r34  = 1, r33
(p18)  stl [r13] = r35,1
      br.ctop loop
    
```



Memory

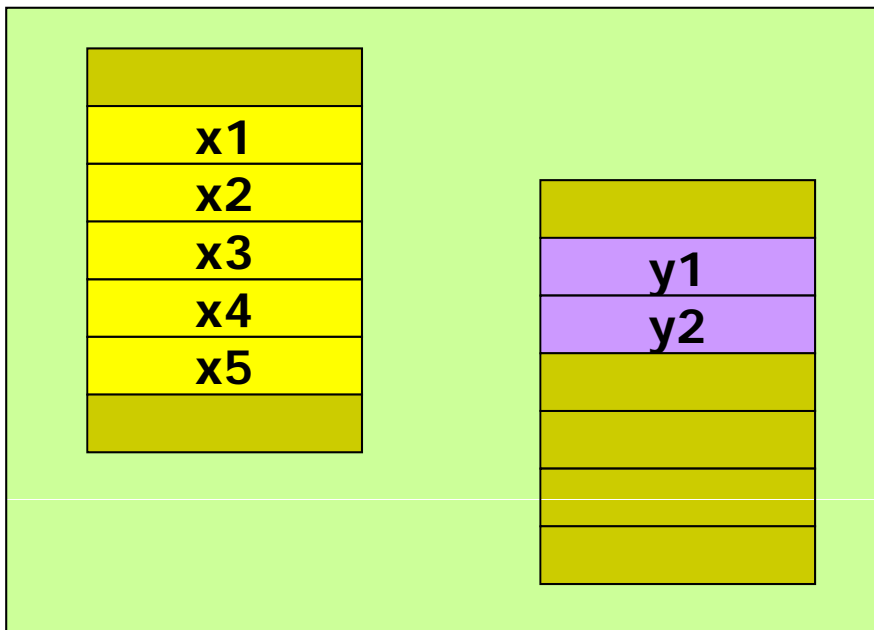

General Registers (Physical)

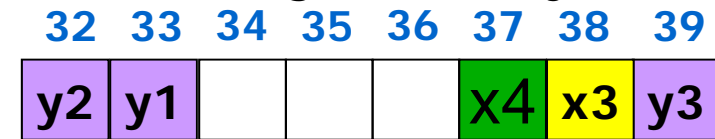

General Registers (Logical)

Predicate Registers



16 17 18

LC



EC



RRB



# Software Pipelining Example in the IA-64

```

loop:
(p16)  ldl r32  = [r12], 1
(p17)  add r34  = 1, r33
(p18)  stl [r13] = r35,1
      br.ctop loop
    
```

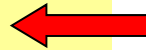

Memory

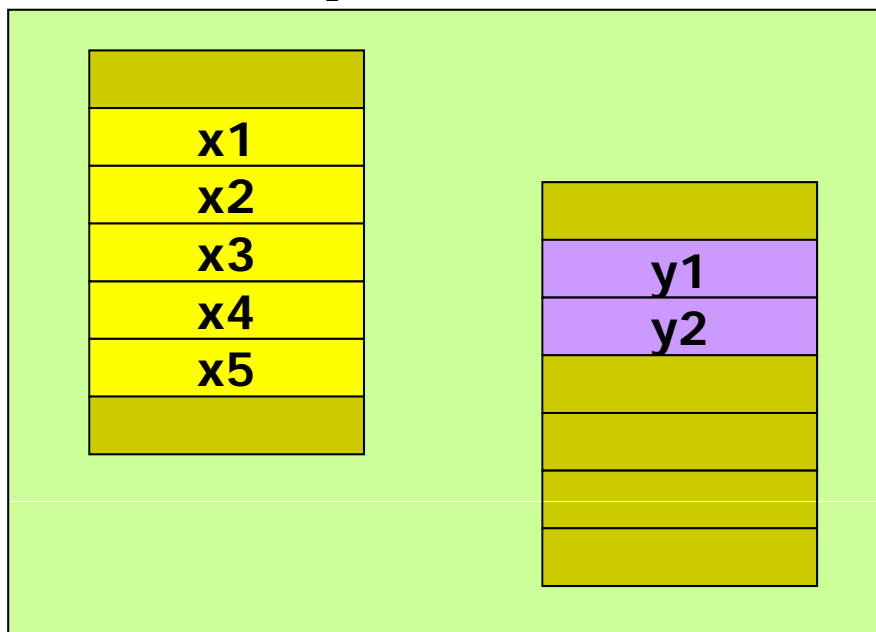

General Registers (Physical)

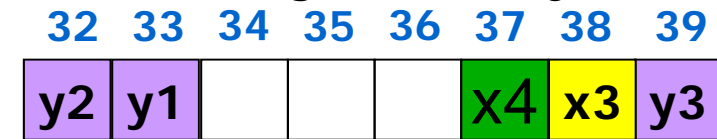

General Registers (Logical)

Predicate Registers

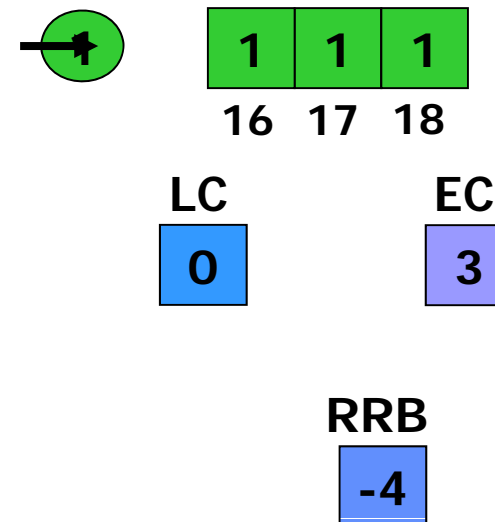

# Software Pipelining Example in the IA-64

```

loop:
(p16)  ldl r32  = [r12], 1
(p17)  add r34  = 1, r33
(p18)  stl [r13] = r35, 1
      br.ctop loop
    
```

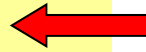

General Registers (Physical)

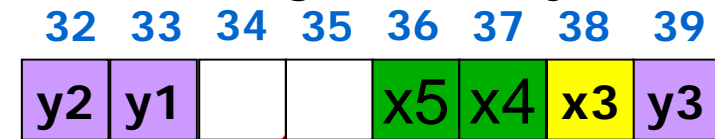

General Registers (Logical)



Memory

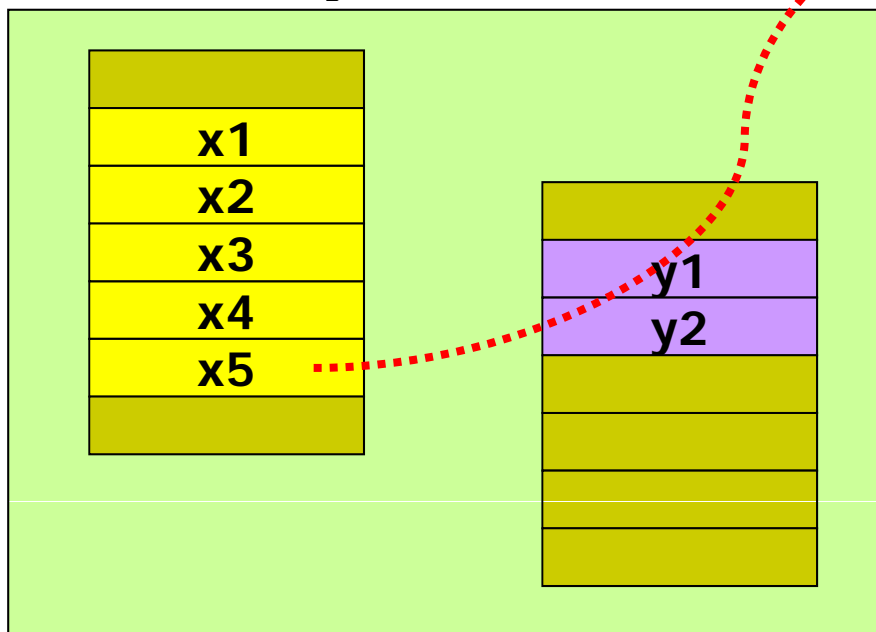

Predicate Registers



16 17 18

LC



EC



RRB



# Software Pipelining Example in the IA-64

```

loop:
(p16) ldl r32 = [r12], 1
(p17) add r34 = 1, r33
(p18) stl [r13] = r35, 1
      br.ctop loop
    
```



Memory

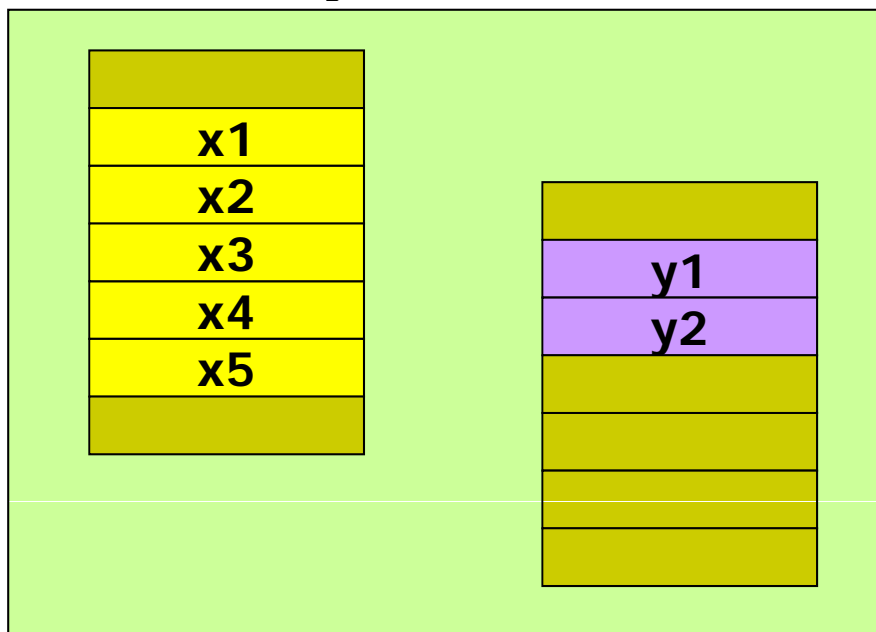

General Registers (Physical)

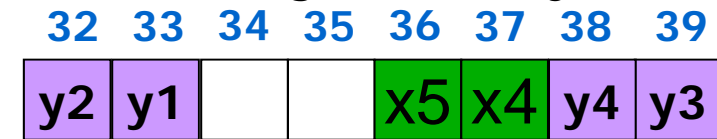

General Registers (Logical)

Predicate Registers



16 17 18

LC



EC



RRB



# Software Pipelining Example in the IA-64

```

loop:
(p16)  ldl r32  = [r12], 1
(p17)  add r34  = 1, r33
(p18)  stl [r13] = r35, 1
      br.ctop loop
    
```

Memory

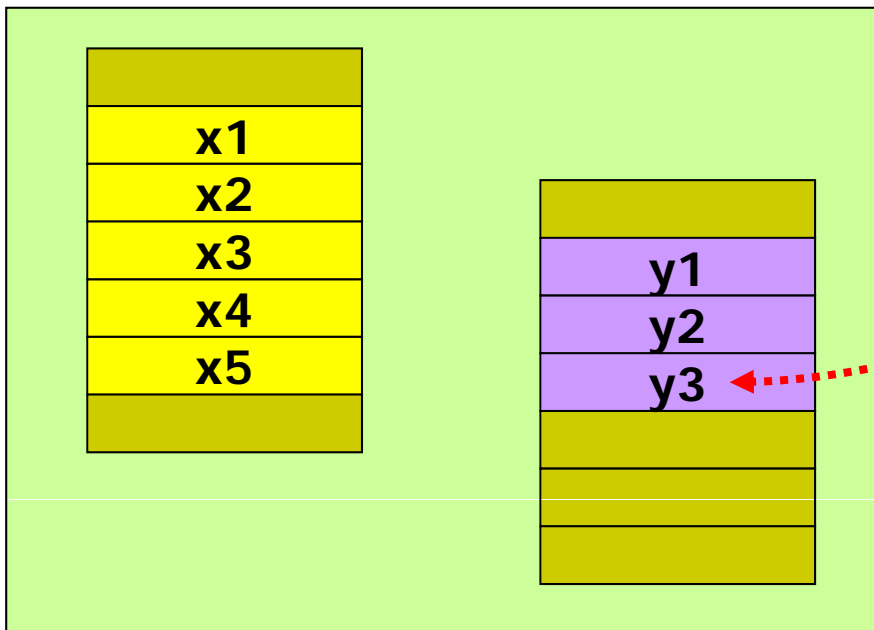

General Registers (Physical)

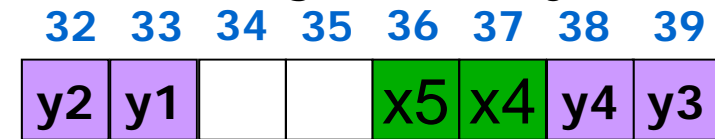

General Registers (Logical)

Predicate Registers



16 17 18

LC



EC



RRB



# Hidden slides...

- ▶ Some hidden slides are not in handout
- ▶ We continue with start of pipeline drain phase

# Software Pipelining Example in the IA-64

```

loop:
(p16)  ldl r32  = [r12], 1
(p17)  add r34  = 1, r33
(p18)  stl [r13] = r35,1
      br.ctop loop
    
```

Memory

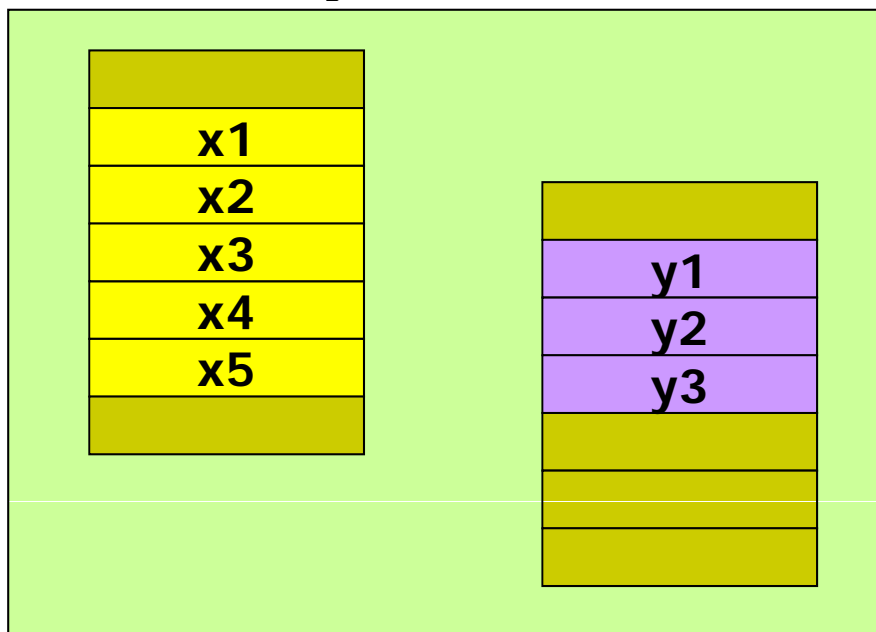

General Registers (Physical)

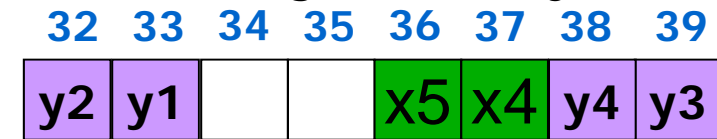

General Registers (Logical)

Predicate Registers

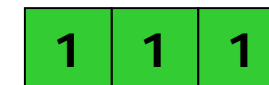

16 17 18

LC



EC



RRB



# Software Pipelining Example in the IA-64

```

loop:
(p16)  ldl r32  = [r12], 1
(p17)  add r34  = 1, r33
(p18)  stl [r13] = r35,1
      br.ctop loop
    
```

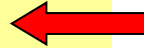

Memory

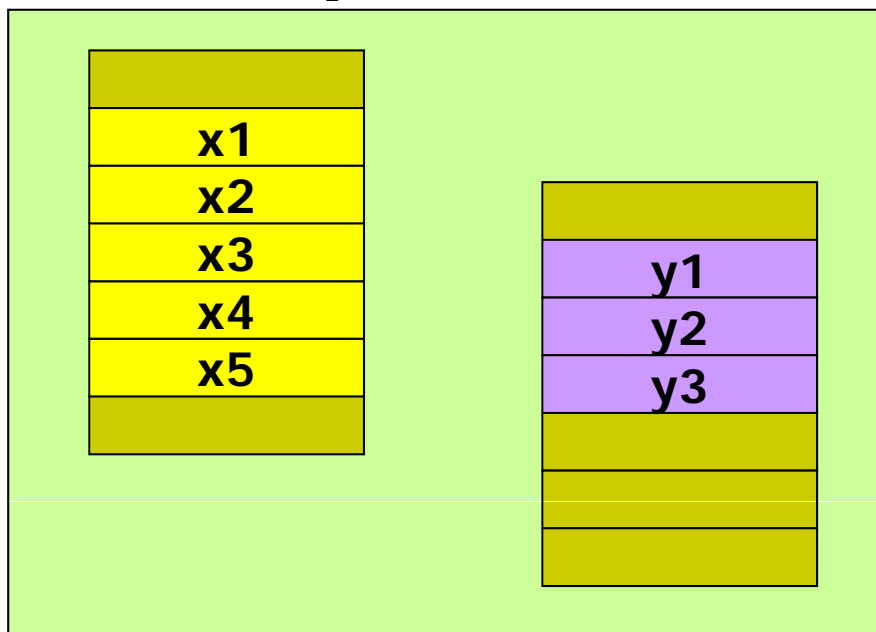

General Registers (Physical)

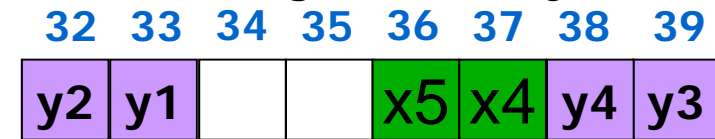

General Registers (Logical)

Predicate Registers

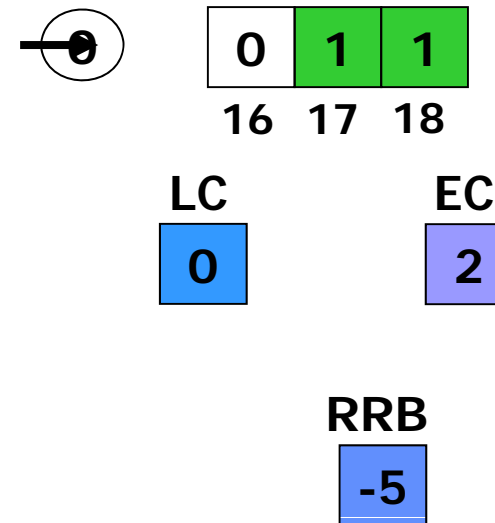

# Software Pipelining Example in the IA-64

```

loop:
(p16)  ldl r32  = [r12], 1
(p17)  add r34  = 1, r33
(p18)  stl [r13] = r35,1
      br.ctop loop
    
```

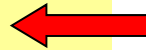

Memory

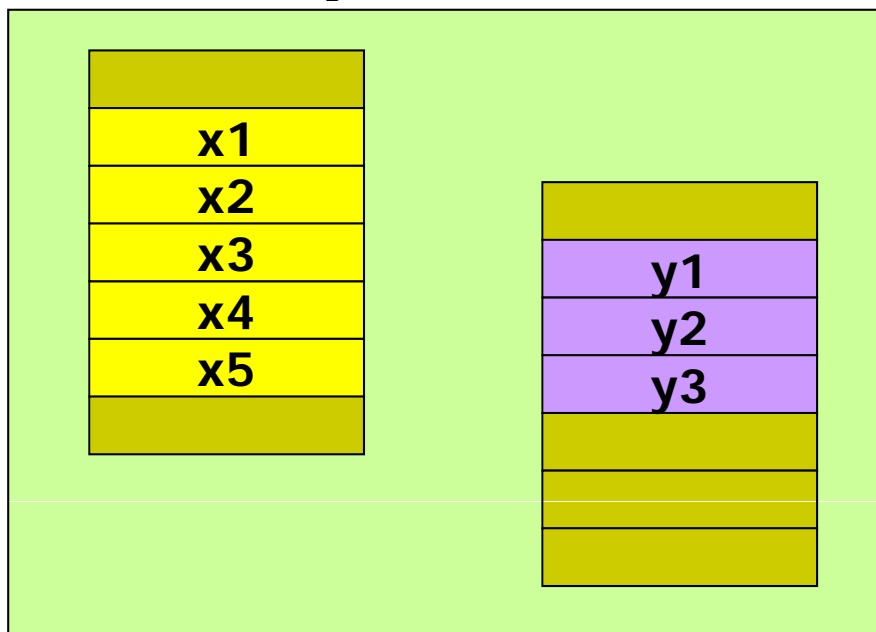

General Registers (Physical)

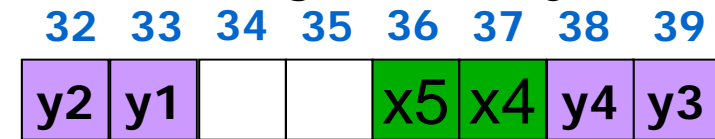

General Registers (Logical)

Predicate Registers

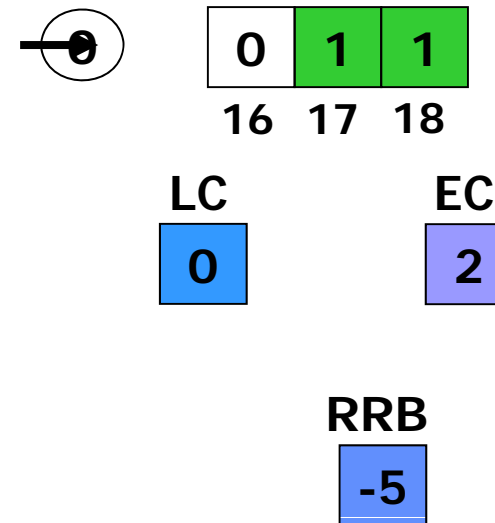

# Software Pipelining Example in the IA-64

```

loop:
(p16)  ldl r32  = [r12], 1
(p17)  add r34  = 1, r33
(p18)  stl [r13] = r35, 1
      br.ctop loop
    
```

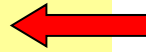

Memory

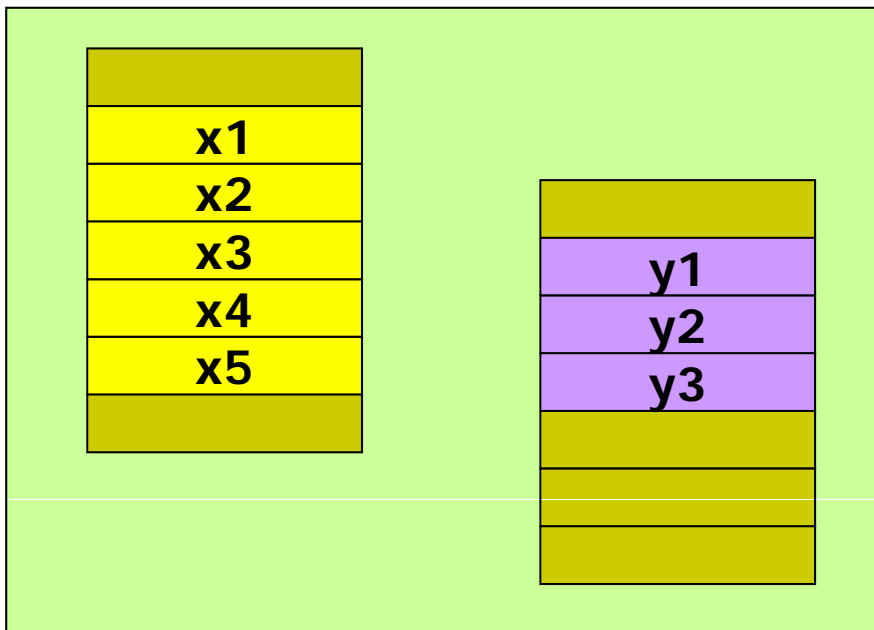

General Registers (Physical)

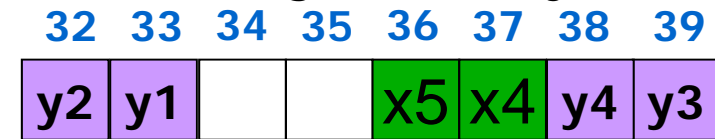

General Registers (Logical)

Predicate Registers

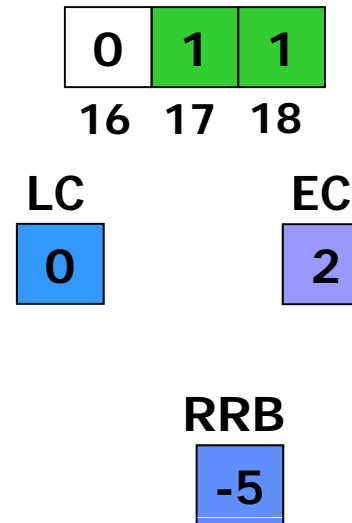

# Software Pipelining Example in the IA-64

```

loop:
(p16)  ldl r32  = [r12], 1
(p17)  add r34  = 1, r33
(p18)  stl [r13] = r35,1
      br.ctop loop
    
```



Memory

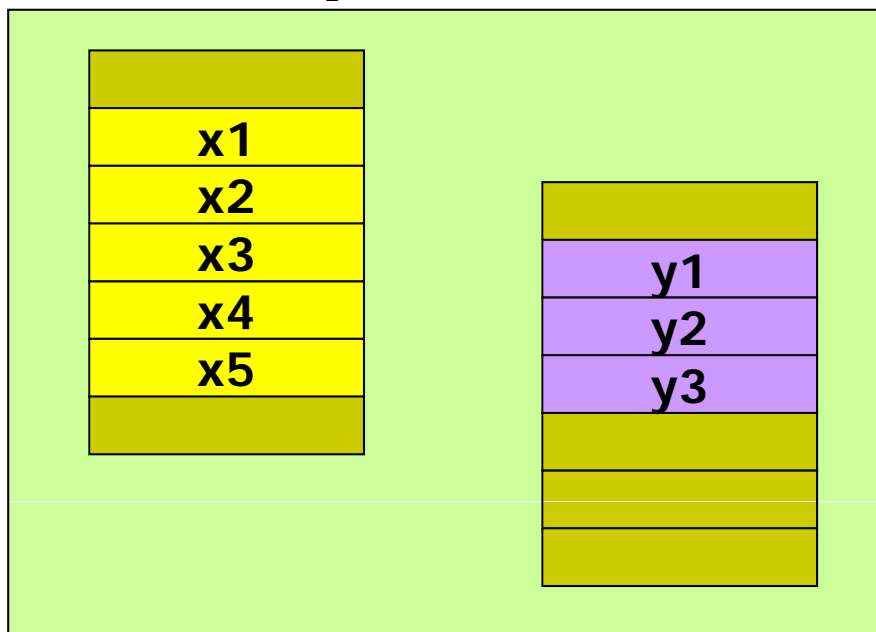

General Registers (Physical)

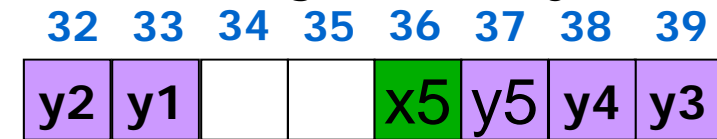

General Registers (Logical)



Predicate Registers



16 17 18

LC



EC



RRB



# Software Pipelining Example in the IA-64

```

loop:
(p16)  ldl r32  = [r12], 1
(p17)  add r34  = 1, r33
(p18)  stl [r13] = r35, 1
      br.ctop loop
    
```

Memory

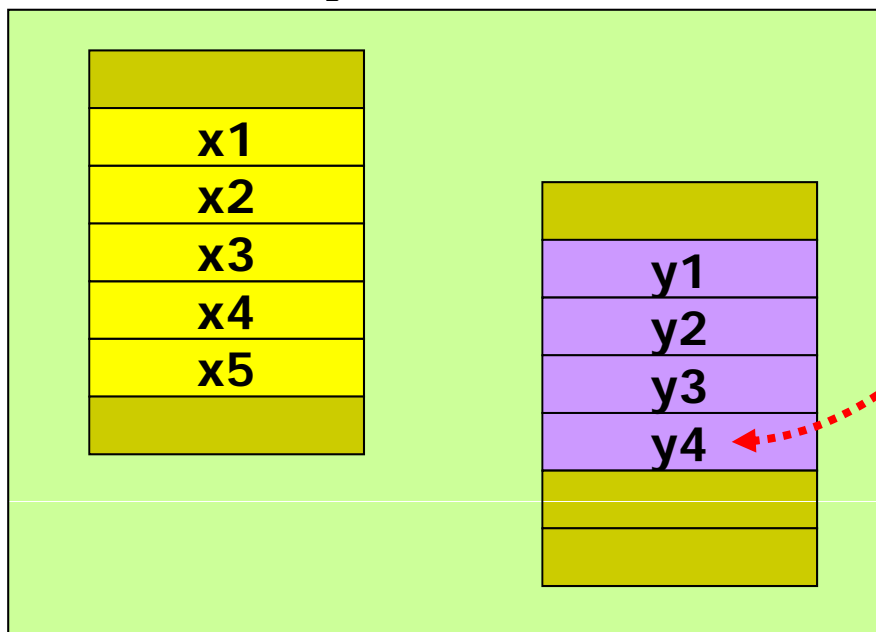

General Registers (Physical)

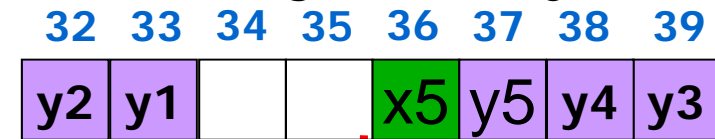

General Registers (Logical)



Predicate Registers

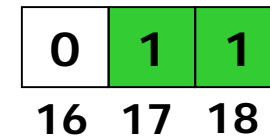

LC



EC



RRB



# Software Pipelining Example in the IA-64

```

loop:
(p16)  ldl r32  = [r12], 1
(p17)  add r34  = 1, r33
(p18)  stl [r13] = r35,1
      br.ctop loop
    
```



Memory

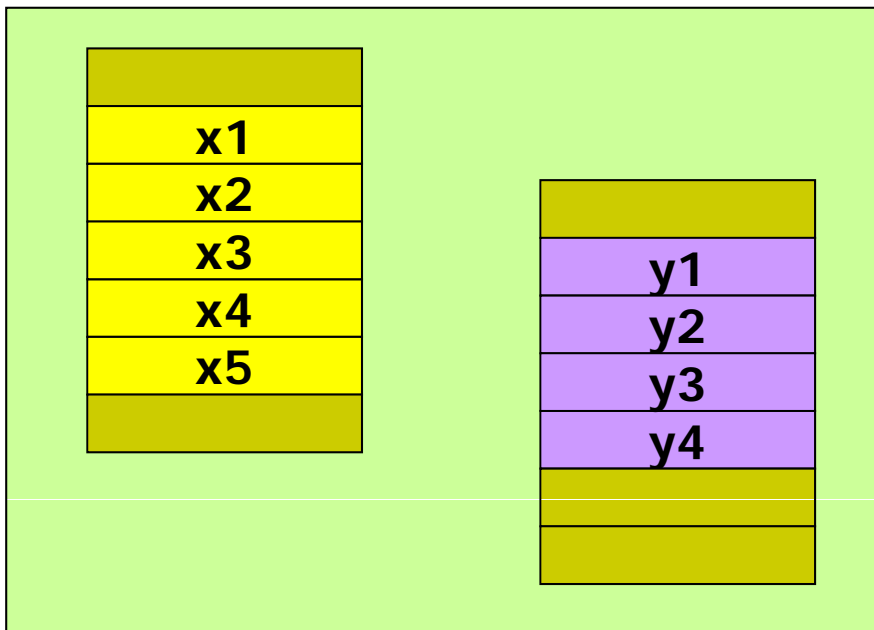

General Registers (Physical)

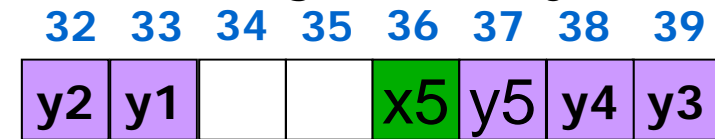

General Registers (Logical)

37 38 39 32 33 34 35 36

Predicate Registers

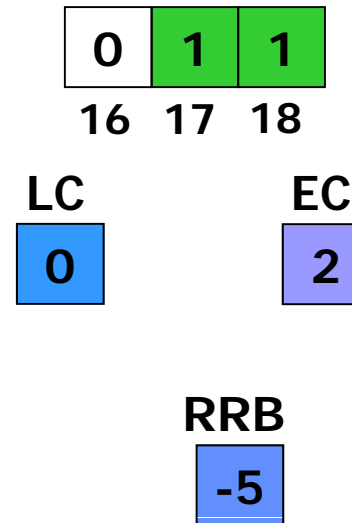

# Software Pipelining Example in the IA-64

```

loop:
(p16)  ldl r32  = [r12], 1
(p17)  add r34  = 1, r33
(p18)  stl [r13] = r35,1
      br.ctop loop
    
```

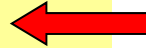

Memory

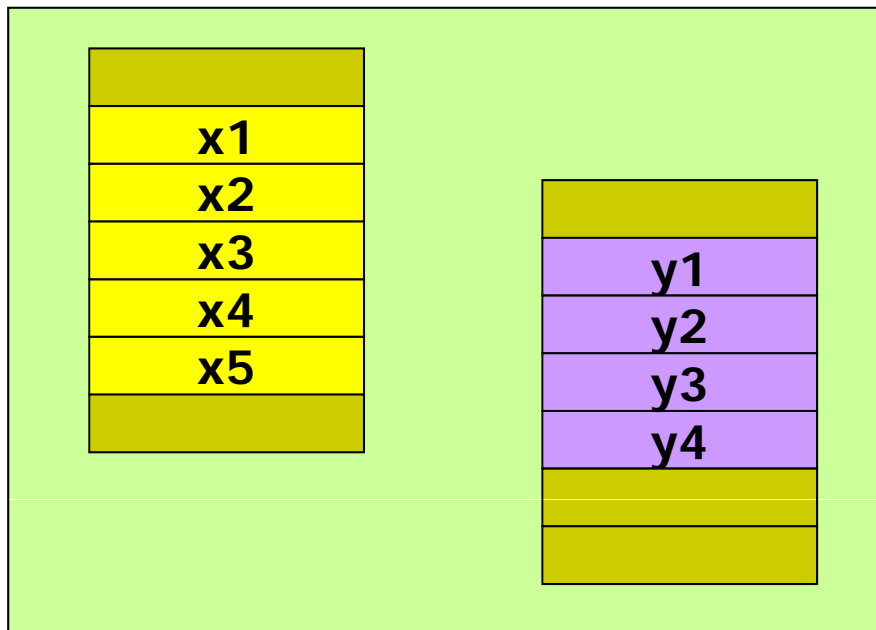

General Registers (Physical)

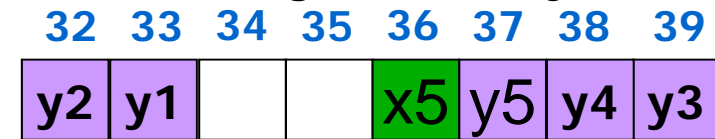

General Registers (Logical)

Predicate Registers

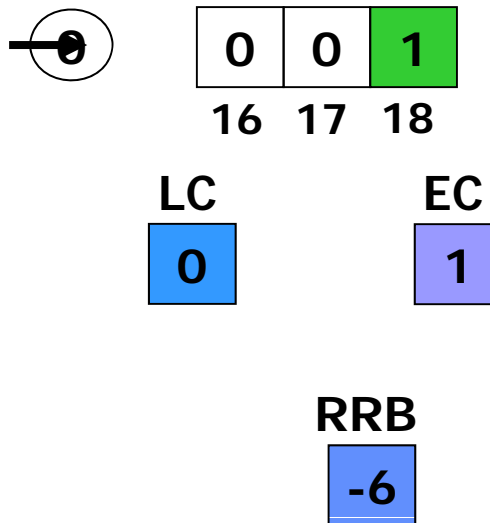

# Software Pipelining Example in the IA-64

```

loop:
(p16)  ldl r32  = [r12], 1
(p17)  add r34  = 1, r33
(p18)  stl [r13] = r35, 1
      br.ctop loop
    
```

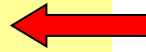

Memory

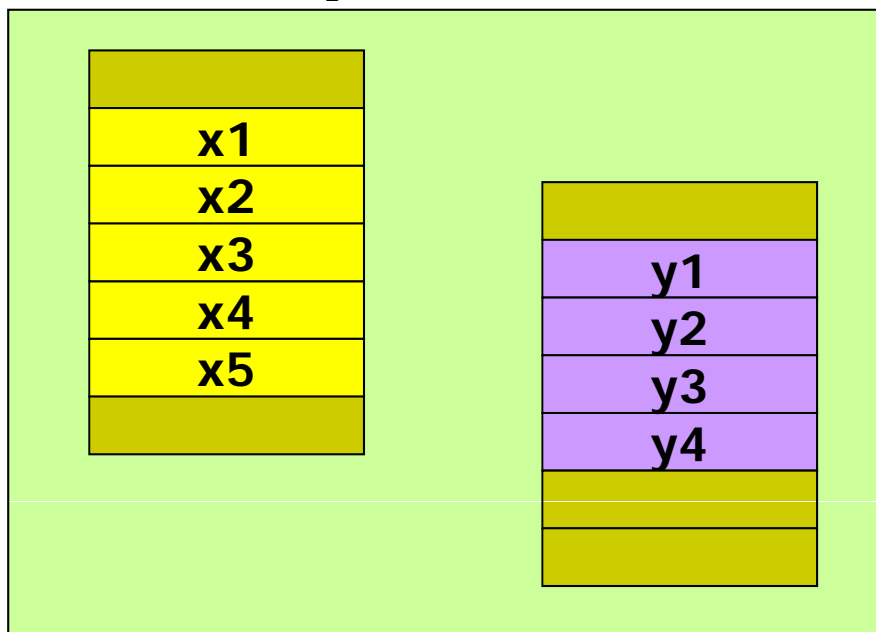

General Registers (Physical)

32	33	34	35	36	37	38	39
y2	y1			x5	y5	y4	y3

General Registers (Logical)

Predicate Registers

0	0	1
16	17	18

LC

0
---

EC

1
---

RRB

-6
----

# Software Pipelining Example in the IA-64

```

loop:
(p16) ldl r32 = [r12], 1
(p17) add r34 = 1, r33
(p18) stl [r13] = r35, 1
      br.ctop loop
    
```



Memory

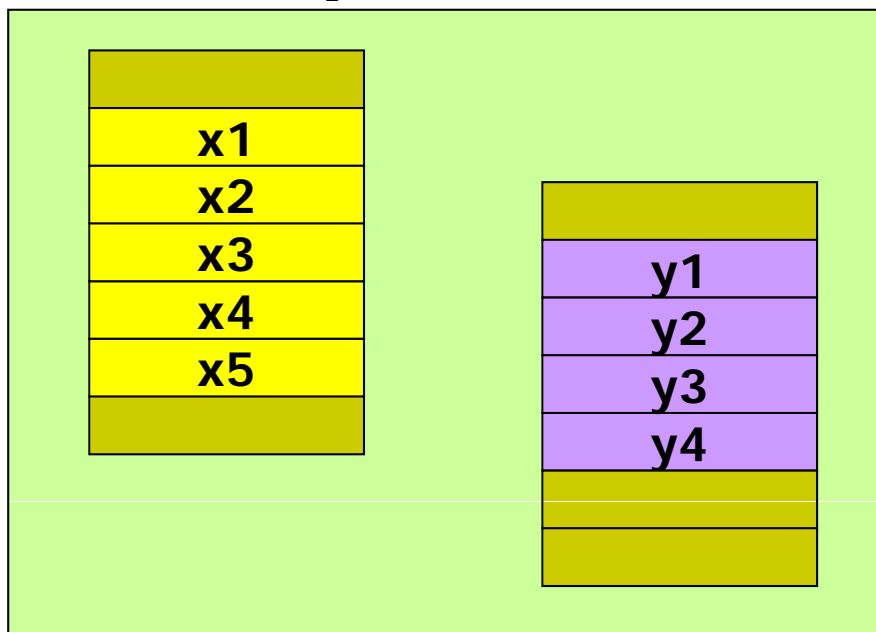

General Registers (Physical)

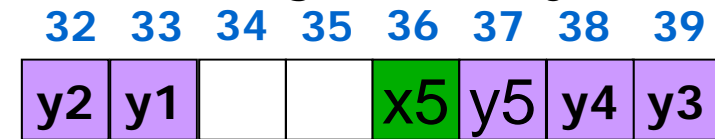

General Registers (Logical)

Predicate Registers

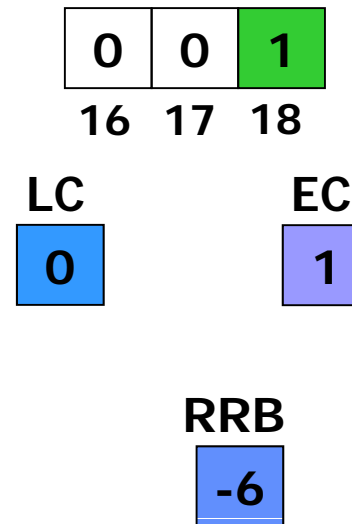

# Software Pipelining Example in the IA-64

```

loop:
(p16)  ldl r32  = [r12], 1
(p17)  add r34  = 1, r33
(p18)  stl [r13] = r35, 1
      br.ctop loop
    
```

Memory

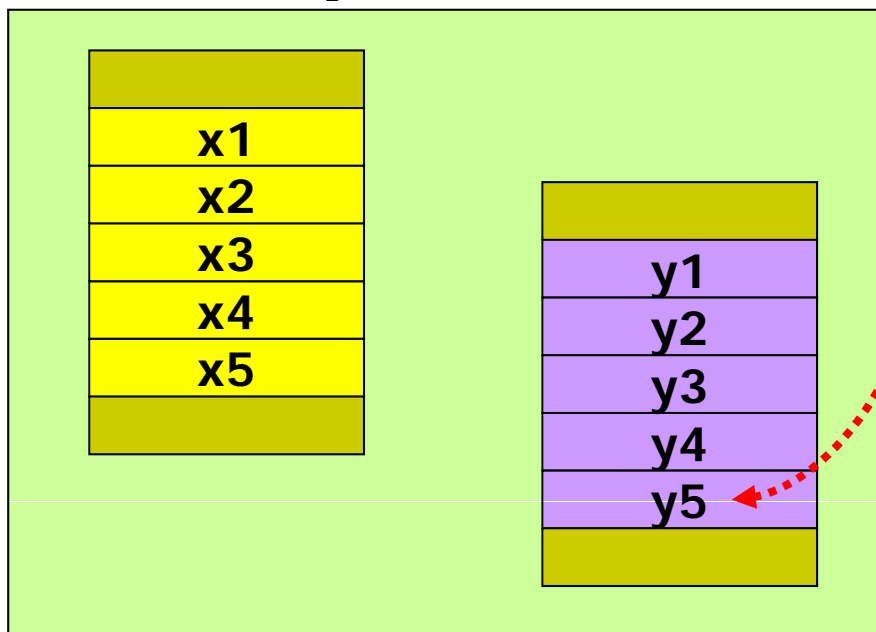

General Registers (Physical)

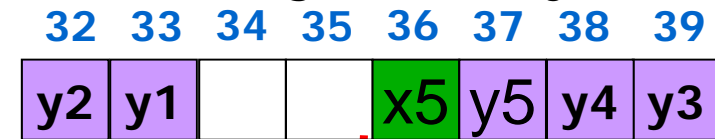

General Registers (Logical)



Predicate Registers

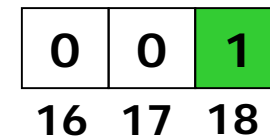

LC



EC



RRB



# Software Pipelining Example in the IA-64

```

loop:
(p16)  ldl r32  = [r12], 1
(p17)  add r34  = 1, r33
(p18)  stl [r13] = r35,1
      br.ctop loop
    
```

Memory

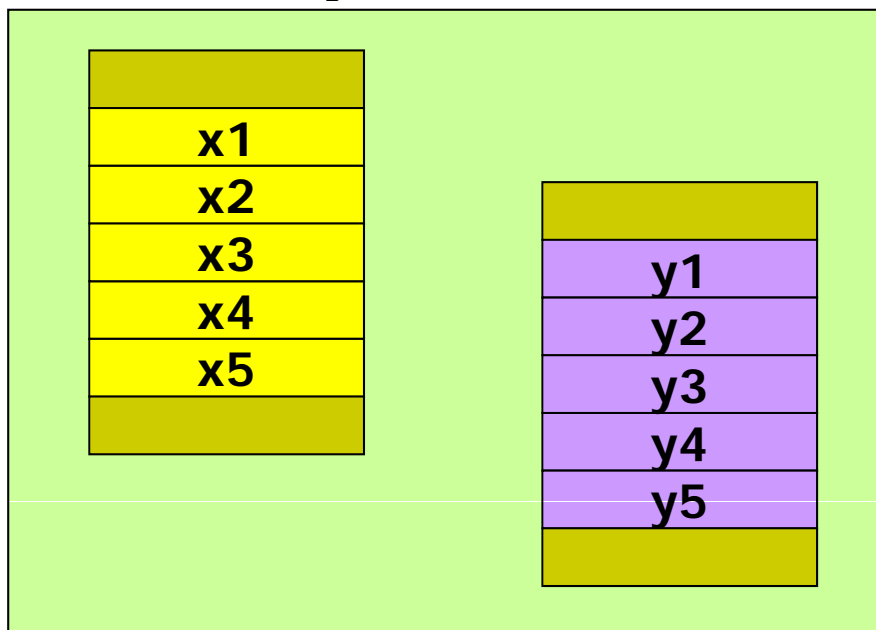

General Registers (Physical)

32	33	34	35	36	37	38	39
y2	y1			x5	y5	y4	y3

General Registers (Logical)

36	37	38	39	32	33	34	35
----	----	----	----	----	----	----	----

Predicate Registers

0	0	1
---	---	---

16 17 18

LC

0
---

EC

1
---

RRB

-6
----

# Software Pipelining Example in the IA-64

```

loop:
(p16)  ldl r32  = [r12], 1
(p17)  add r34  = 1, r33
(p18)  stl [r13] = r35,1
      br.ctop loop
    
```

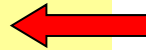

Memory

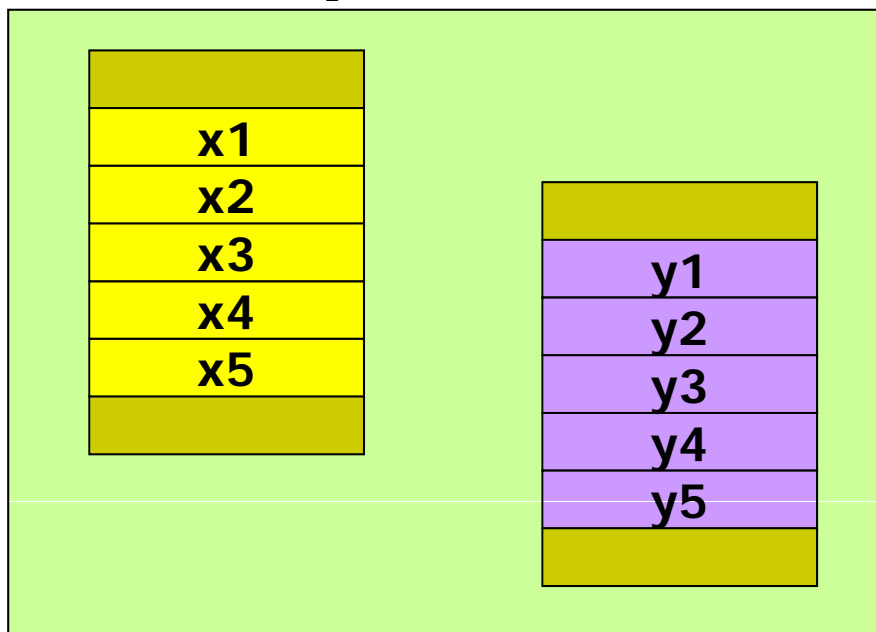

General Registers (Physical)

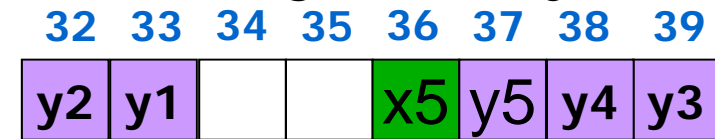

General Registers (Logical)



Predicate Registers

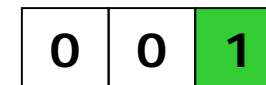

16 17 18

LC



EC



RRB



# Software Pipelining Example in the IA-64

```

loop:
(p16)  ldl r32  = [r12], 1
(p17)  add r34  = 1, r33
(p18)  stl [r13] = r35,1
      br.ctop loop
    
```

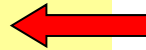

Memory

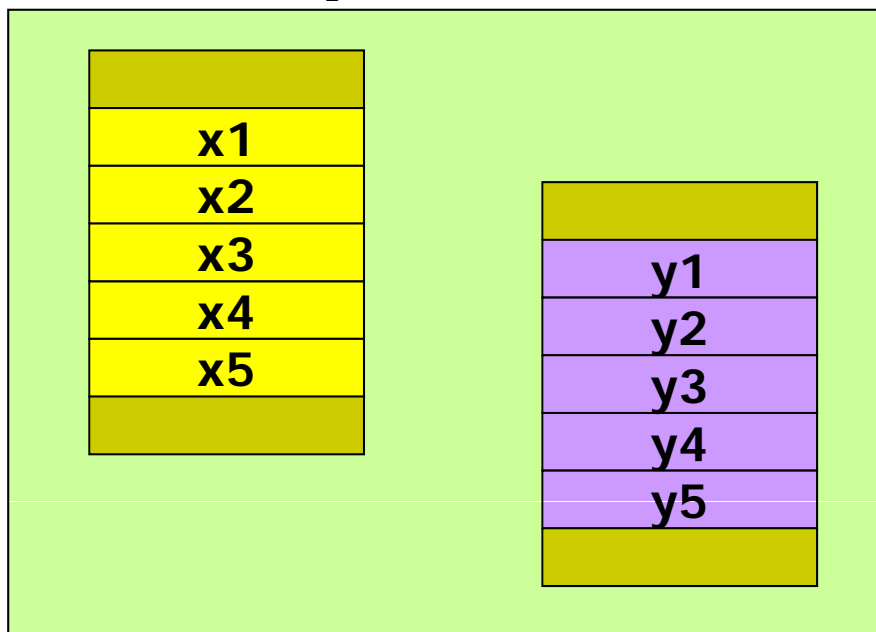

General Registers (Physical)

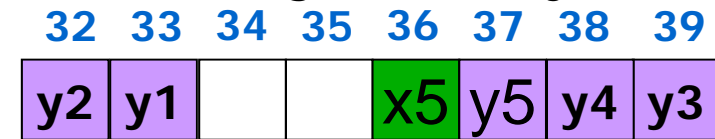

General Registers (Logical)

Predicate Registers

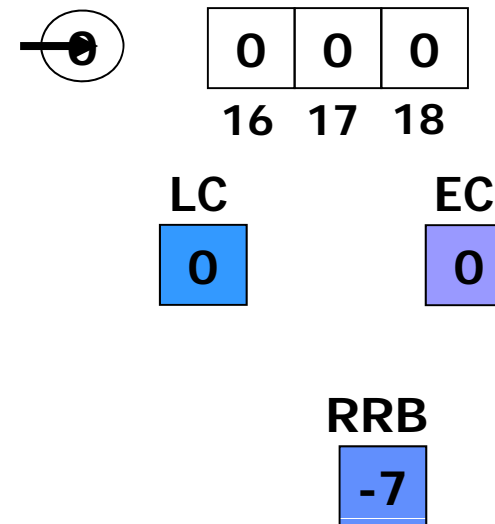

## Cache

- ▶ 32KB L1 (2 cycle)
- ▶ 96KB L2 (7 cycle)
- ▶ 2 or 4 MB L3 (off chip)

▶ 133 MHz 64-bit bus

▶ SpecFP: 711

▶ SpecInt: 404

▶ 36-bit addresses (64GB)

# Itanium™ Processor Silicon

*(Copyright: Intel at Hotchips '00)*

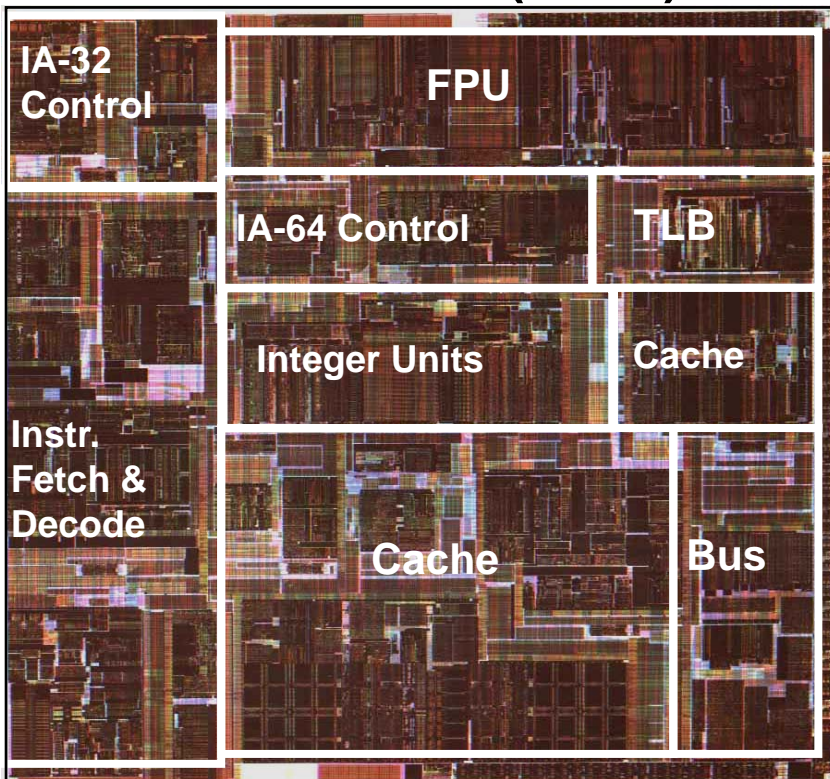

**Core Processor Die**

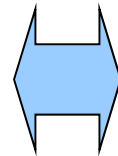

**4 x 1MB L3 cache**

# Itanium™ Machine Characteristics

*(Copyright: Intel at Hotchips '00)*

<b>Frequency</b>	<b>800 MHz</b>
<b>Transistor Count</b>	<b>25.4M CPU; 295M L3</b>
<b>Process</b>	<b>0.18u CMOS, 6 metal layer</b>
<b>Package</b>	<b>Organic Land Grid Array</b>
<b>Machine Width</b>	<b>6 insts/clock (4 ALU/MM, 2 Ld/St, 2 FP, 3 Br)</b>
<b>Registers</b>	<b>14 ported 128 GR &amp; 128 FR; 64 Predicates</b>
<b>Speculation</b>	<b>32 entry ALAT, Exception Deferral</b>
<b>Branch Prediction</b>	<b>Multilevel 4-stage Prediction Hierarchy</b>
<b>FP Compute Bandwidth</b>	<b>3.2 GFlops (DP/EP); 6.4 GFlops (SP)</b>
<b>Memory -&gt; FP Bandwidth</b>	<b>4 DP (8 SP) operands/clock</b>
<b>Virtual Memory Support</b>	<b>64 entry ITLB, 32/96 2-level DTLB, VHPT</b>
<b>L2/L1 Cache</b>	<b>Dual ported 96K Unified &amp; 16KD; 16KI</b>
<b>L2/L1 Latency</b>	<b>6 / 2 clocks</b>
<b>L3 Cache</b>	<b>4MB, 4-way s.a., BW of 12.8 GB/sec;</b>
<b>System Bus</b>	<b>2.1 GB/sec; 4-way Glueless MP</b> <b>Scalable to large (512+ proc) systems</b>

# Itanium™ EPIC Design Maximizes SW-HW Synergy

(Copyright: Intel at Hotchips '00)

Architecture Features programmed by compiler:

Branch Hints

Explicit Parallelism

Register Stack & Rotation

Predication

Data & Control Speculation

Memory Hints

Micro-architecture Features in hardware:

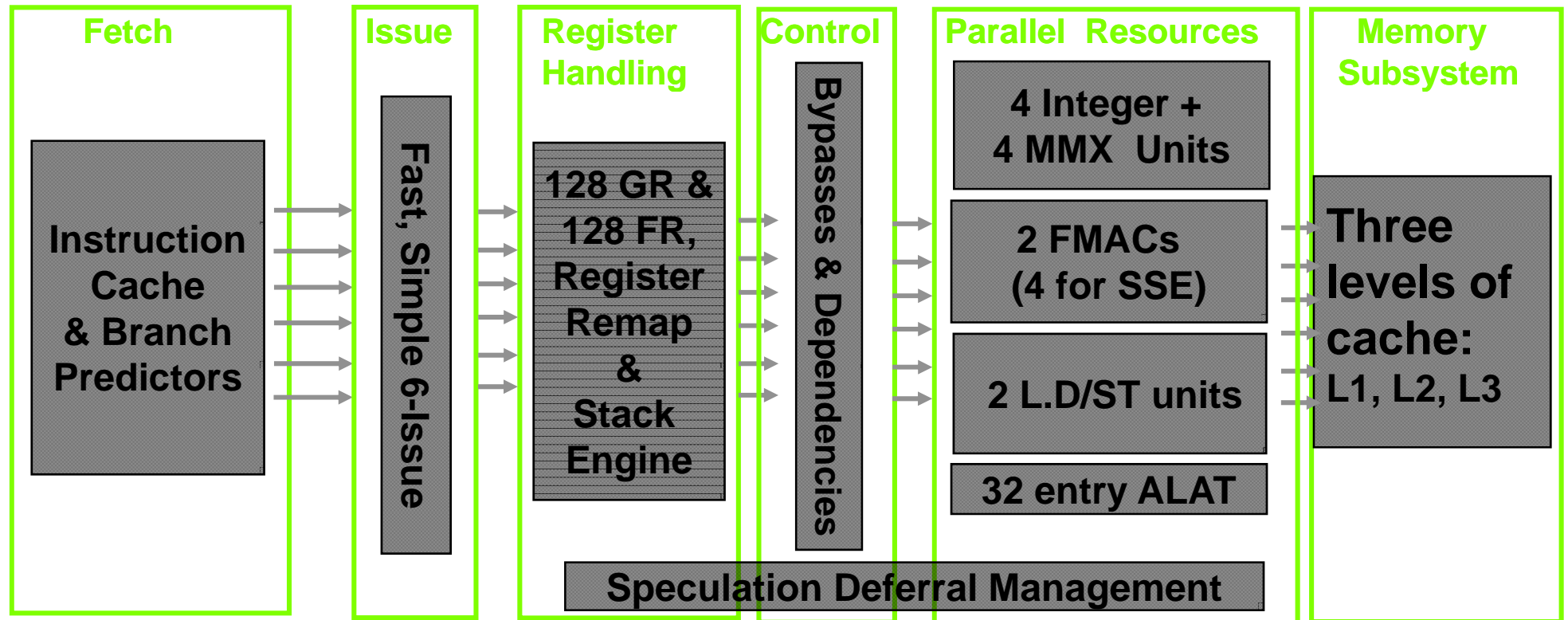

# 10 Stage In-Order Core Pipeline

(Copyright: Intel at Hotchips '00)

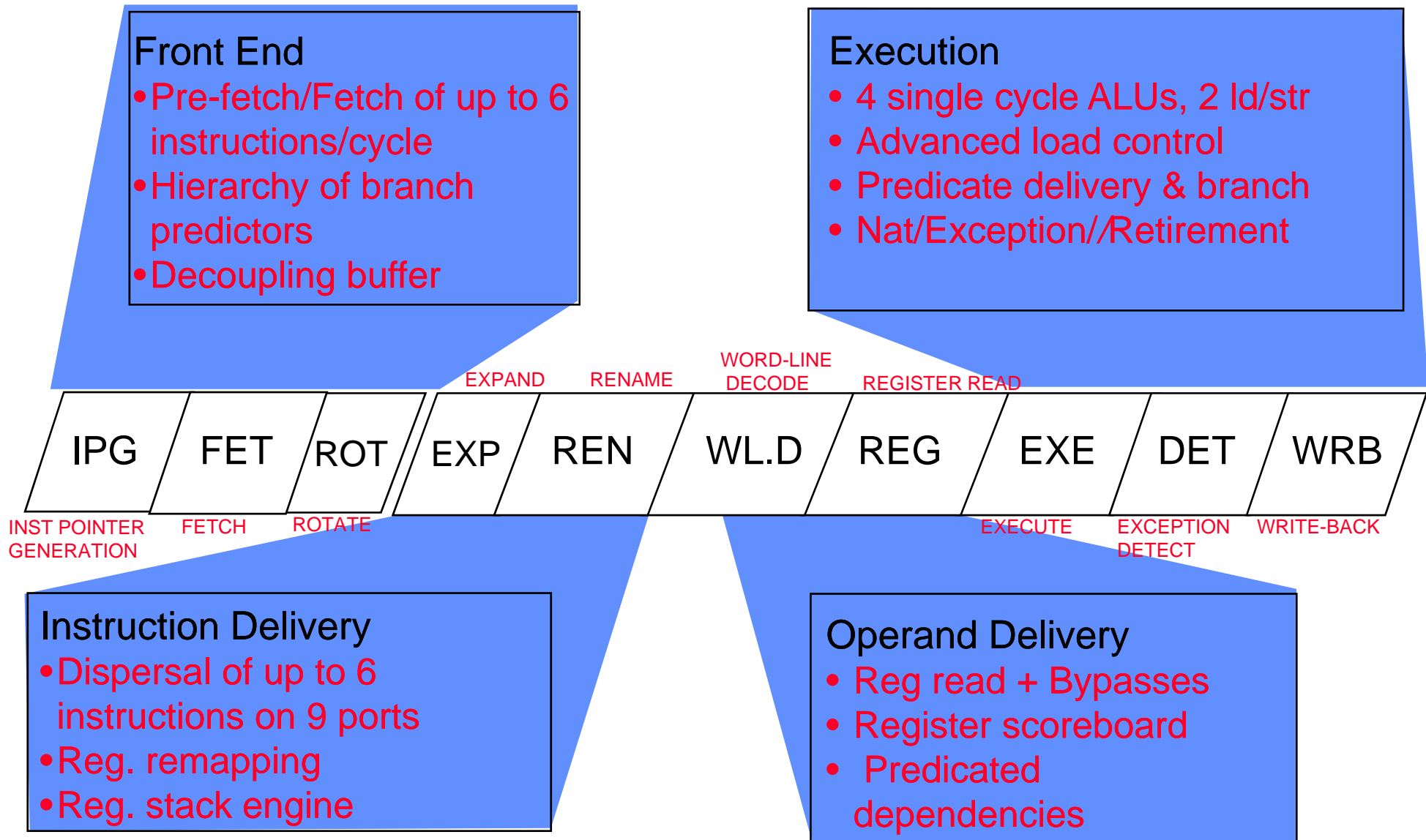

# Itanium processor 10-stage pipeline

- ▶ **Front-end (stages IPG, Fetch, and Rotate):**  
prefetches up to 32 bytes per clock (2 bundles) into a prefetch buffer, which can hold up to 8 bundles (24 instructions)
  - ▶ Branch prediction is done using a multilevel adaptive predictor like P6 microarchitecture
- ▶ **Instruction delivery (stages EXP and REN):**  
distributes up to 6 instructions to the 9 functional units
  - ▶ Implements registers renaming for both rotation and register stacking.

# Itanium processor 10-stage pipeline

- ▶ **Operand delivery (WLD and REG):** accesses register file, performs register bypassing, accesses and updates a register scoreboard, and checks predicate dependences.
  - ▶ Scoreboard used to detect when individual instructions can proceed, so that a stall of 1 instruction in a bundle need not cause the entire bundle to stall
- ▶ **Execution (EXE, DET, and WRB):** executes instructions through ALUs and load/store units, detects exceptions and posts NaTs, retires instructions and performs write-back
  - ▶ Deferred exception handling for speculative instructions is supported by providing the equivalent of poison bits, called NaTs for Not a Thing, for the GPRs (which makes the GPRs effectively 65 bits wide), and NaT Val (Not a Thing Value) for FPRs (already 82 bits wide)

# Itanium 2

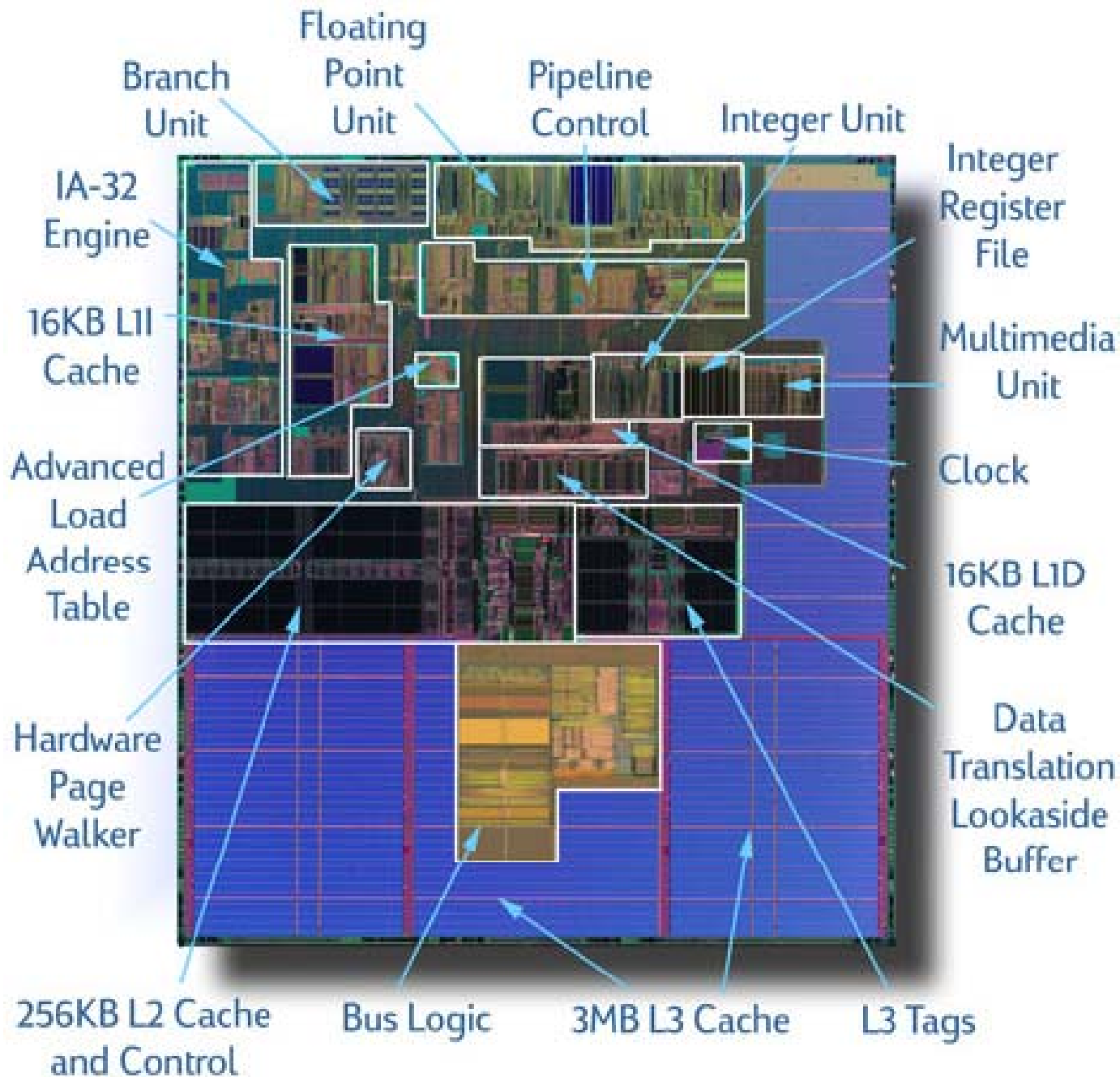

## Caches

- 32KB L1 (1 cycle)
  - 256KB L2 (5 cycle)
  - 3 MB L3 (on chip)
- **200 MHz 128-bit Bus**
- **SpecFP: 1356**
- **SpecInt: 810**
- **44-bit addresses (18TB)**

➤ **221M transistors**

➤ **19.5 x 21.6 mm**

➤ <http://cpus.hp.com/technical/references/>

# Comments on Itanium

- ▶ Remarkably, the Itanium has many of the features more commonly associated with the dynamically-scheduled pipelines
  - ▶ strong emphasis on branch prediction, register renaming, scoreboarding, a deep pipeline with many stages before execution (to handle instruction alignment, renaming, etc.), and several stages following execution to handle exception detection
- ▶ Surprising that an approach whose goal is to rely on compiler technology and simpler HW seems to be at least as complex as dynamically scheduled processors!

# EPIC/IA-64/Itanium principles

## ▶ Start loads early

- ▶ advance loads - move above stores when alias analysis is incomplete
- ▶ speculative loads - move above branches

## ▶ Predication to eliminate many conditional branches

- ▶ 64 predicate registers
- ▶ almost every instruction is predicated

## ▶ register rich

- ▶ 128 integer registers (64 bits each)
- ▶ 128 floating-point registers

## ▶ Independence architecture

- ▶ VLIW flavor, but fully interlocked (i.e., no delay slots)
- ▶ three 41-bit instruction syllables per 128-bit "bundle"
- ▶ each bundle contains 5 "template bits" which specify independence of following syllables (within bundle and between bundles)

## ▶ unbundled branch architecture

- ▶ eight branch registers
- ▶ multiway branches

## ▶ Rotating register files

- ▶ lower 48 of the predicate registers rotate
- ▶ lower 96 of the integer registers rotate

## Itanium Timeline

- 1981: **Bob Rau** leads Polycyclic Architecture project at TRW/ESL
- 1983: **Josh Fisher** describes ELI-512 VLIW design and trace scheduling
- 1983-1988: Rau at Cydrome works on VLIW design called Cydra-5, but company folds 1988
- 1984-1990: **Fisher at Multiflow works on VLIW design** called Trace, but company folds 1990
- 1988: Dick Lampman at HP hires Bob Rau and **Mike Schlansker** from Cydrome and also gets IP rights from Cydrome
- 1989: Rau & Schlansker begin FAST (Fine-grained Architecture & Software Technologies) research project at HP; later develop HP PlayDoh architecture
- 1990-1993: Bill Worley leads PA-WW (Precision Architecture Wide-Word) effort at HP Labs to be successor to PA-RISC architecture; also called SP-PA (Super-Parallel Processor Architecture) & SWS (SuperWorkStation)
- HP hires Josh Fisher, input to PA-WW
- Input to PA-WW from Hitachi team, led by Yasuyuki Okada
- 1991: Hans Mulder joins Intel to start work on a 64-bit architecture
- 1992: Worley recommends HP seek a semiconductor manufacturing partner
- 1993: HP starts effort to develop PA-WW as a product
- Dec 1993: HP investigates partnership with Intel
- June 1994: announcement of cooperation between HP & Intel; PA-WW starting point for joint design; John Crawford of Intel leads joint team
- 1997: the term EPIC is coined
- Oct 1997: Microprocessor Forum presentations by Intel and HP
- July 1998: Carole Dulong of Intel, "The IA-64 Architecture at Work," IEEE Computer
- Feb 1999: release of ISA details of IA-64
- 2001: Intel marketing prefers IPF (Itanium Processor Family) to IA-64
- May 2001 - Itanium (Merced)
- July 2002 - Itanium 2 (McKinley)
- Aug 2004: "Itanium sales fall \$13.4bn shy of \$14bn forecast" (The Register)
- Dec 2004: HP transfers last of Itanium development to Intel

# Itanium – rumours exaggerated?



<http://www.intel.com/technology/computing/hw10041.htm>

- **NASA's 10,240-processor Columbia supercomputer is built from 20 Altix systems, each powered by 512 Intel Itanium 2 processors. Peak performance 42.7 TeraFlops. Runs Linux. (Image courtesy of Silicon Graphics, Inc.)**
- **SGI has similar contracts at**
  - Japan Atomic Energy Research Institute (JAERI) (2048 processors eventually)
  - Leibniz Rechenzentrum Computing Center (LRZ) at the Bavarian Academy of Sciences and Humanities, Munich (3328 processors eventually)

## Top 20 SPEC systems

Top 20 SPECint2000						Top 20 SPECfp2000				
#	MHz	Processor	int peak	int base	Full results	MHz	Processor	fp peak	fp base	Full results
1	2933	Core 2 Duo EE	3119	3108	<a href="#">HTML</a>	2300	POWER5+	3642	3369	<a href="#">HTML</a>
2	3000	Xeon 51xx	3102	3089	<a href="#">HTML</a>	1600	DC Itanium 2	3098	3098	<a href="#">HTML</a>
3	2666	Core 2 Duo	2848	2844	<a href="#">HTML</a>	3000	Xeon 51xx	3056	2811	<a href="#">HTML</a>
4	2660	Xeon 30xx	2835	2826	<a href="#">HTML</a>	2933	Core 2 Duo EE	3050	3048	<a href="#">HTML</a>
5	3000	Opteron	2119	1942	<a href="#">HTML</a>	2660	Xeon 30xx	3044	2763	<a href="#">HTML</a>
6	2800	Athlon 64 FX	2061	1923	<a href="#">HTML</a>	1600	Itanium 2	3017	3017	<a href="#">HTML</a>
7	2800	Opteron AM2	1960	1749	<a href="#">HTML</a>	2667	Core 2 Duo	2850	2847	<a href="#">HTML</a>
8	2300	POWER5+	1900	1820	<a href="#">HTML</a>	1900	POWER5	2796	2585	<a href="#">HTML</a>
9	3733	Pentium 4 E	1872	1870	<a href="#">HTML</a>	3000	Opteron	2497	2260	<a href="#">HTML</a>
10	3800	Pentium 4 Xeon	1856	1854	<a href="#">HTML</a>	2800	Opteron AM2	2462	2230	<a href="#">HTML</a>
11	2260	Pentium M	1839	1812	<a href="#">HTML</a>	3733	Pentium 4 E	2283	2280	<a href="#">HTML</a>
12	3600	Pentium D	1814	1810	<a href="#">HTML</a>	2800	Athlon 64 FX	2261	2086	<a href="#">HTML</a>
13	2167	Core Duo	1804	1796	<a href="#">HTML</a>	2700	PowerPC 970MP	2259	2060	<a href="#">HTML</a>
14	3600	Pentium 4	1774	1772	<a href="#">HTML</a>	2160	SPARC64 V	2236	2094	<a href="#">HTML</a>
15	3466	Pentium 4 EE	1772	1701	<a href="#">HTML</a>	3730	Pentium 4 Xeon	2150	2063	<a href="#">HTML</a>
16	2700	PowerPC 970MP	1706	1623	<a href="#">HTML</a>	3600	Pentium D	2077	2073	<a href="#">HTML</a>
17	2600	Athlon 64	1706	1612	<a href="#">HTML</a>	3600	Pentium 4	2015	2009	<a href="#">HTML</a>
18	2000	Pentium 4 Xeon LV	1668	1663	<a href="#">HTML</a>	2600	Athlon 64	1829	1700	<a href="#">HTML</a>
19	2160	SPARC64 V	1620	1501	<a href="#">HTML</a>	1700	POWER4+	1776	1642	<a href="#">HTML</a>
20	1600	Itanium 2	1590	1590	<a href="#">HTML</a>	3466	Pentium 4 EE	1724	1719	<a href="#">HTML</a>

### With Auto-parallelisation

Top 20 SPECint2000					Top 20 SPECfp2000					
#	MHz	Processor	int peak	int base	Full results	MHz	Processor	fp peak	fp base	Full results
1						2100	POWER5+	4051	3210	<a href="#">HTML</a>
2						3000	Opteron	3538	2851	<a href="#">HTML</a>
3						2600	Opteron AM2	3338	2711	<a href="#">HTML</a>
4						1200	UltraSPARC III Cu	1344	1074	<a href="#">HTML</a>

**Aces Hardware  
 analysis of SPEC  
 benchmark data  
[http://www.aces  
 hardware.com/S  
 PECmine/top.jsp](http://www.aceshardware.com/SPECmine/top.jsp)**

<http://www.spec.org/cpu2006/results/cpu2006.html>

# Summary#1: Hardware versus Software Speculation Mechanisms

- ▶ **To speculate extensively, must be able to disambiguate memory references**
  - ▶ **Much easier in HW than in SW for code with pointers**
- ▶ **HW-based speculation works better when control flow is unpredictable, and when HW-based branch prediction is superior to SW-based branch prediction done at compile time**
  - ▶ **Mispredictions mean wasted speculation**
- ▶ **HW-based speculation maintains precise exception model even for speculated instructions**
- ▶ **HW-based speculation does not require compensation or bookkeeping code**

# Summary#2: Hardware versus Software Speculation Mechanisms

## cont'd

- ▶ **Compiler-based approaches may benefit from the ability to see further in the code sequence, resulting in better code scheduling**
- ▶ **HW-based speculation with dynamic scheduling does not require different code sequences to achieve good performance for different implementations of an architecture**
  - ▶ **may be the most important in the long run?**

# Summary #3: Software Scheduling

- ▶ **Instruction Level Parallelism (ILP) found either by compiler or hardware.**
- ▶ **Loop level parallelism is easiest to see**
  - ▶ SW dependencies/compiler sophistication determine if compiler can unroll loops
  - ▶ Memory dependencies hardest to determine => Memory disambiguation
  - ▶ Very sophisticated transformations available
- ▶ **Trace Scheduling to Parallelize If statements**
- ▶ **Superscalar and VLIW:  $CPI < 1$  ( $IPC > 1$ )**
  - ▶ Dynamic issue vs. Static issue
  - ▶ More instructions issue at same time => larger hazard penalty
  - ▶ Limitation is often number of instructions that you can successfully fetch and decode per cycle