

The SunnyBank Trust Portal v2.0

Presented By:

AUCHARUZ Sonum
CHONG Jung-Ming
CHOUDHRY Usman
DEMAUGRE Matthieu
LAMPADARIDIS Antonios

2009-2010

The Sunnybank Trust

- Established in 1989
- Supports adults with learning disabilities in the boroughs of Epsom and Ewell
- Solely dependant on donations
- Supported by 130 volunteers who provide services to more than 300 persons

The Project



- Version 1.0 developed in December
- Limitations identified by the Trust
- ***Scope of the project:*** Produce version 2.0
- Version 2.0 includes:
 - Improvements on existing functionality
 - New features

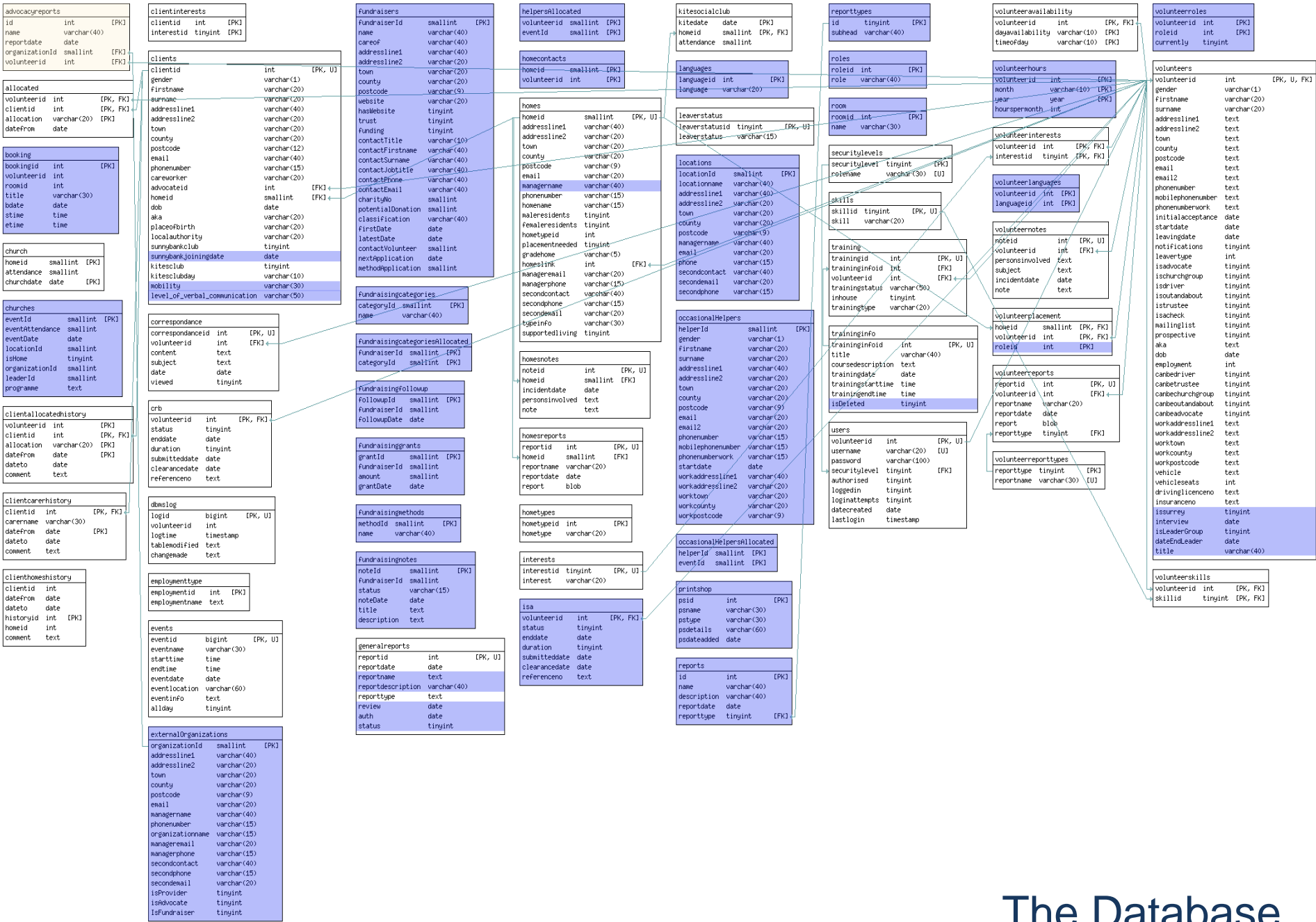

The Database

Technologies Used



- Database back-end: MySQL



- Web front-end:

- PHP,
- Javascript,
- AJAX,
- script.aculo.us

- Other: FPDF, GD Library, Cron Scheduling

AJAX

script.aculo.us
it's about the user interface, baby!



Portal

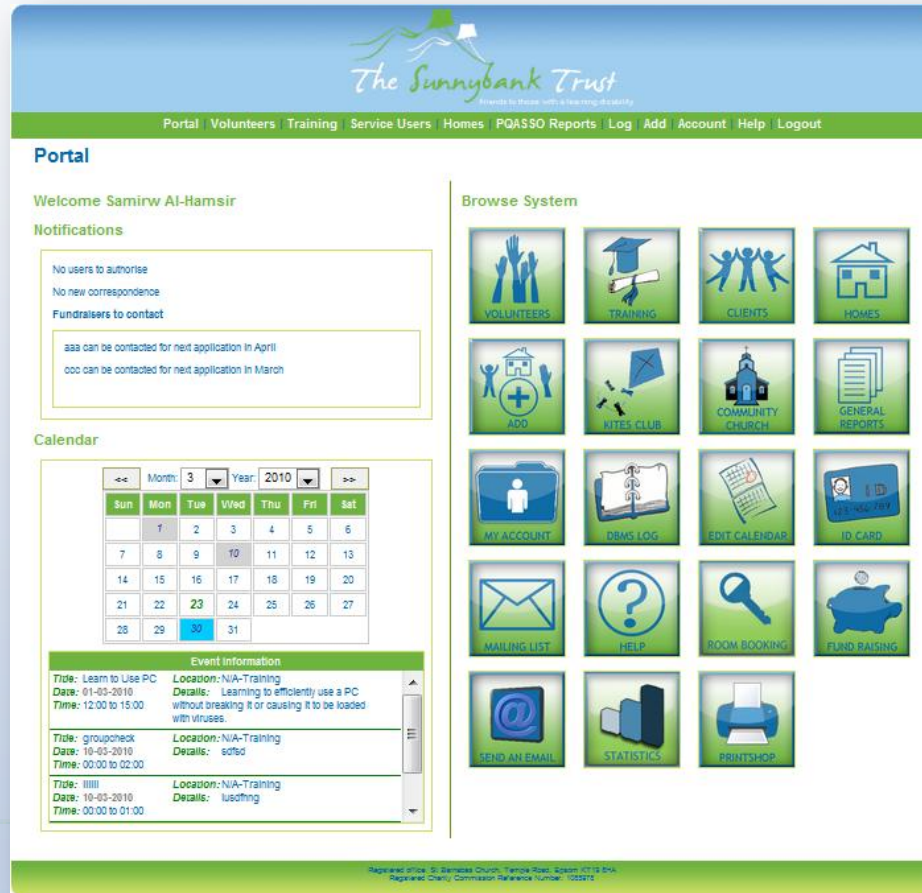

The Sunnybank Trust
Friends to those with a learning disability

Portal | Volunteers | Training | Service Users | Homes | PQASSO Reports | Log | Add | Account | Help | Logout

Portal

Welcome Samirw Al-Hamsir

Notifications

No users to authorise
No new correspondence
Fundraisers to contact

aaa can be contacted for next application in April
ooo can be contacted for next application in March

Calendar

Month: 3 Year: 2010

Sun	Mon	Tue	Wed	Thu	Fri	Sat
	1	2	3	4	5	6
7	8	9	10	11	12	13
14	15	16	17	18	19	20
21	22	23	24	25	26	27
28	29	30	31			

Event Information

Title: Learn to Use PC Date: 01-03-2010 Time: 12:00 to 15:00	Location: N/A-Training Details: Learning to efficiently use a PC without breaking it or causing it to be loaded with viruses.
Title: groupcheck Date: 10-05-2010 Time: 00:00 to 02:00	Location: N/A-Training Details: sorted
Title: IHHH Date: 10-05-2010 Time: 00:00 to 01:00	Location: N/A-Training Details: lushing

Browse System

- VOLUNTEERS
- TRAINING
- CLIENTS
- HOUSES
- ADD
- KITES CLUB
- COMMUNITY CHURCH
- GENERAL REPORTS
- MY ACCOUNT
- DBMS LOG
- EDIT CALENDAR
- ID CARD
- MAILING LIST
- HELP
- ROOM BOOKING
- FUND RAISING
- SEND AN EMAIL
- STATISTICS
- PRINTSHOP

Registered office: St. Barnabas Church, Tenack Road, Sisson, KT13 8WJ.
Registered Charity Commission Reference Number: 1022574



- Reports divided into categories
- Reports can be reviewed (PQASSO only)
- Search by Title, Description or Date
- PQASSO administrator notified about pending reviews





- Allows for members to create printable mailing lists
- Mailing Lists by Single or by Multiple Groups
- Improve the sizing and layout of mailing labels
- Generation By Birthday.

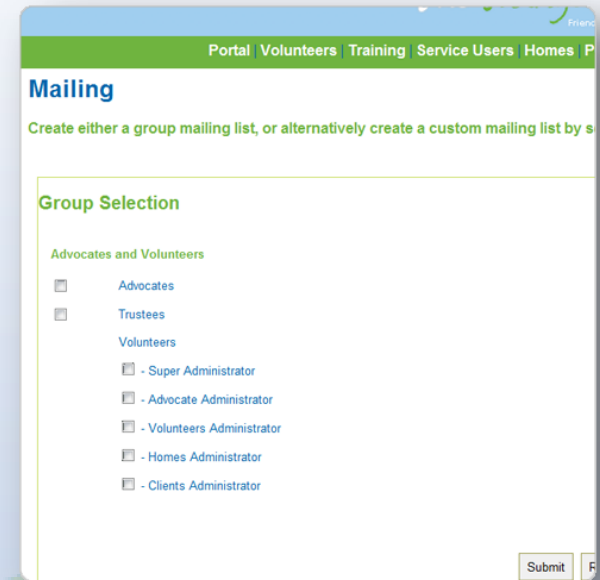

Portal | Volunteers | Training | Service Users | Homes | P

Mailing

Create either a group mailing list, or alternatively create a custom mailing list by s

Group Selection

Advocates and Volunteers

- Advocates
- Trustees

Volunteers

- Super Administrator
- Advocate Administrator
- Volunteers Administrator
- Homes Administrator
- Clients Administrator

Submit



- Version 1.0 provided a web interface with a long log table

- Version 2.0 prints the log entries into PDF files for archiving
- Only the most recent log entries are shown in the interface

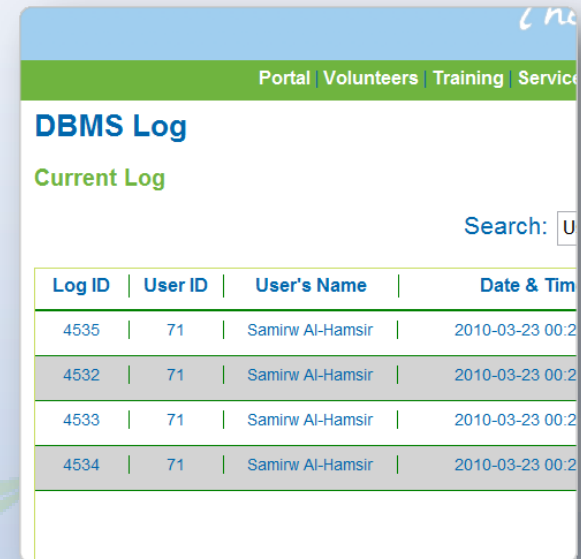

Portal | Volunteers | Training | Services

DBMS Log

Current Log

Search:

Log ID	User ID	User's Name	Date & Time
4535	71	Samirw Al-Hamsir	2010-03-23 00:2
4532	71	Samirw Al-Hamsir	2010-03-23 00:2
4533	71	Samirw Al-Hamsir	2010-03-23 00:2
4534	71	Samirw Al-Hamsir	2010-03-23 00:2



- Before: 1 table, 3 fields
- Now: 6 tables, ~60 fields
- The user can manage all features of adding and editing in the same section

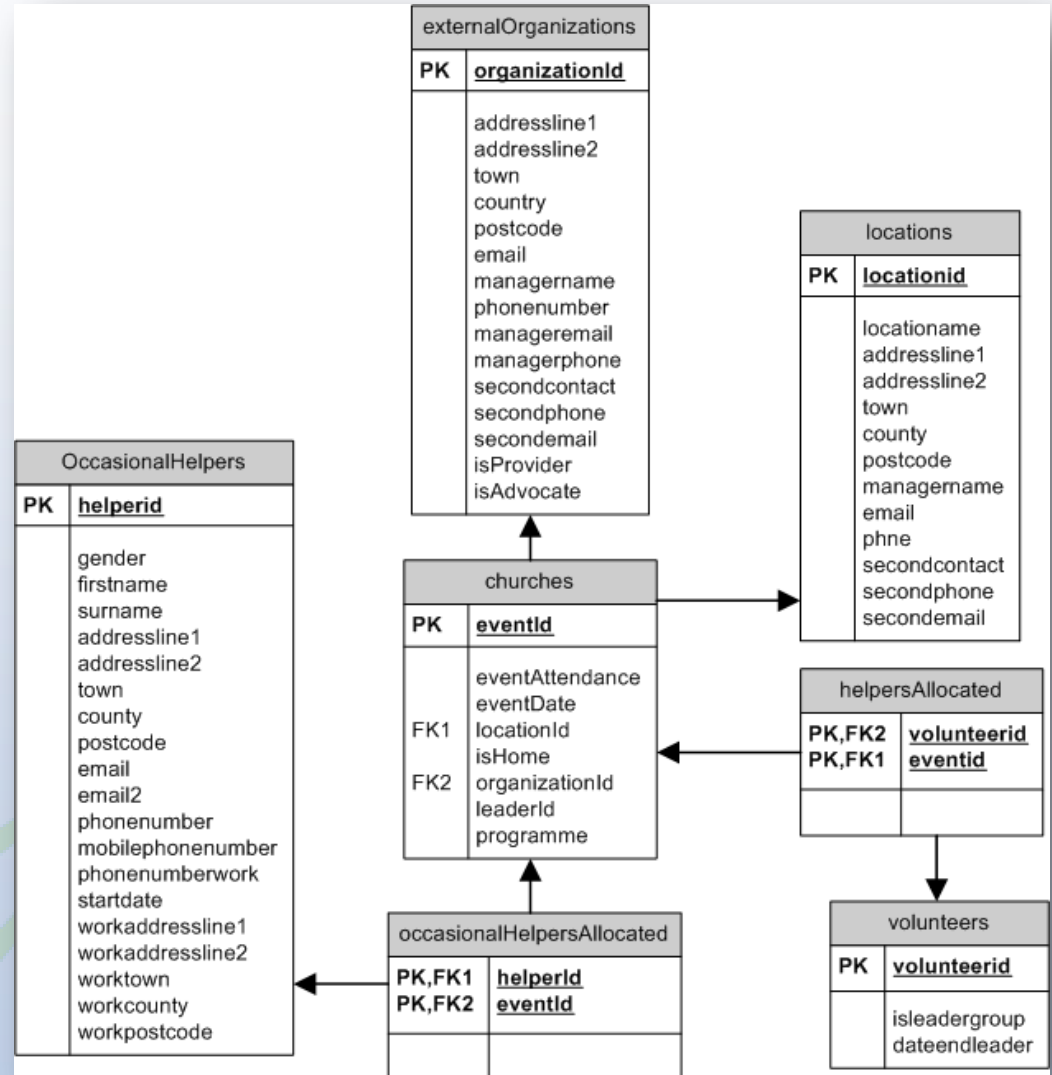



- Dynamic addition of volunteers as contacts of each home
- Allocation of Volunteers by their roles to each home
- Allocation of Clients to each home
- Ownership and Managers Details

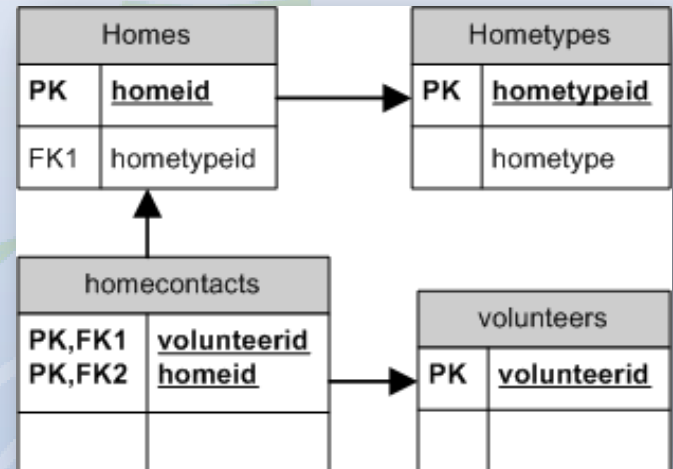



- Allocate volunteer with a specific role to a service user

- Provide enhanced interface for service users
 - Level of Verbal Communication,
 - Mobility, and
 - SunnyBank Club joining date

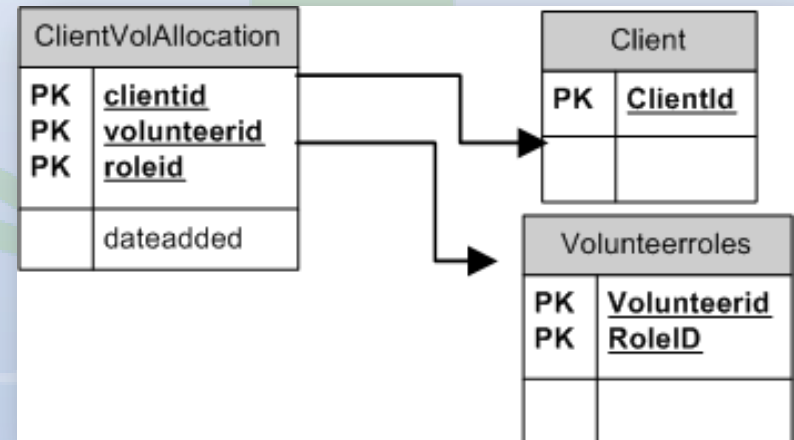



- More information stored
- All volunteers' roles are included
- Export volunteer data to CSV
- Upload Advocacy Reports

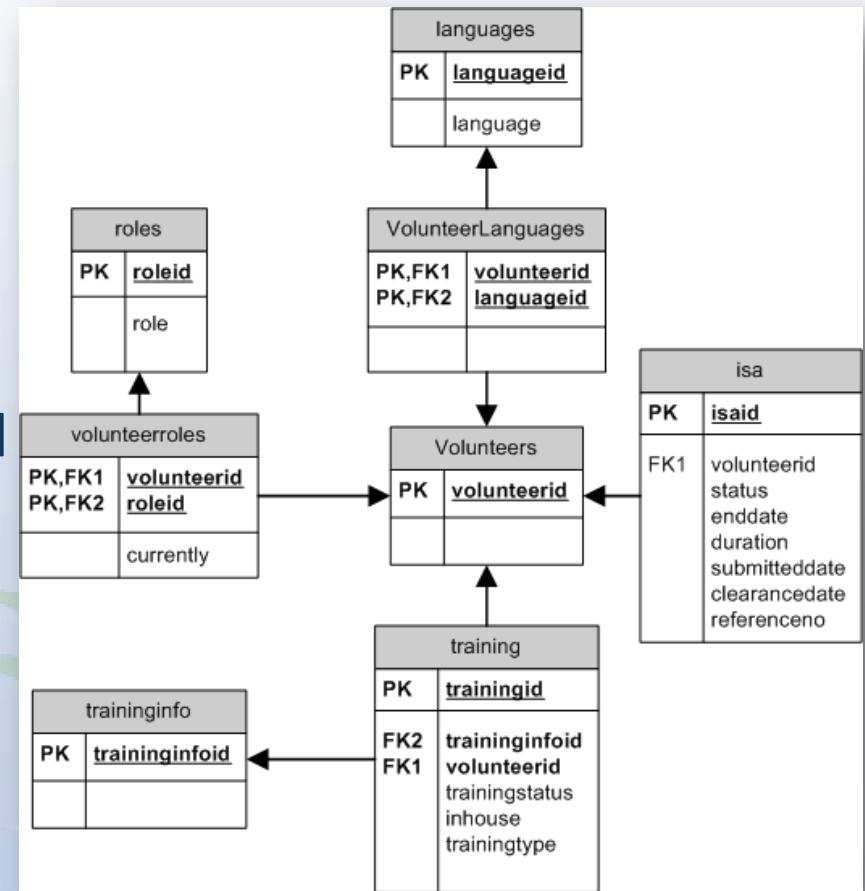



- Allows Members to email Volunteers
- Ability to Send to Many
- Secured from Attacks

Portal | Volunteers | Training | Service

Send an Email to a Volunteer

Select Volunteer(s)

Name Search:	<input type="text" value="Spongeb"/>	Show/Hide Users List
Selected Users:	spongebob squarepants,	
Subject:	HI SPONGEBOB!	
Message:(Note: For security purposes, a copy is stored on our servers. Please do not send privileged information via this system.)	I hope that you are well today and no	



- Volunteers are required to attend training
- Some training events are role – specific
- Bulk Add Members to Training
- The Trust needs to keep track of Attendance
- Show Attendance List



- The Trust needs to provide evidence of its work
- Relevant data is gathered
- Personalised good – looking charts are generated
- Ability to Filter Graphs
- PHP GD is used

Advanced Search & Export of Data

- Data needs to be exported and stored locally
- Available for the following sections:
 - Volunteers
 - Homes
 - Service Users
 - Fund-raising
- Search results stored in CSV files
- Format of CSV files:
 - < Search criteria >
 - < Extracted fields >
 - < Search results >



- Rooms booked for Trust activities
- Room booking feature reduces communication overhead between Administrators.
- Trustees and Administrators responsible for bookings
- Check availability feature
- Extensible design, can support more rooms

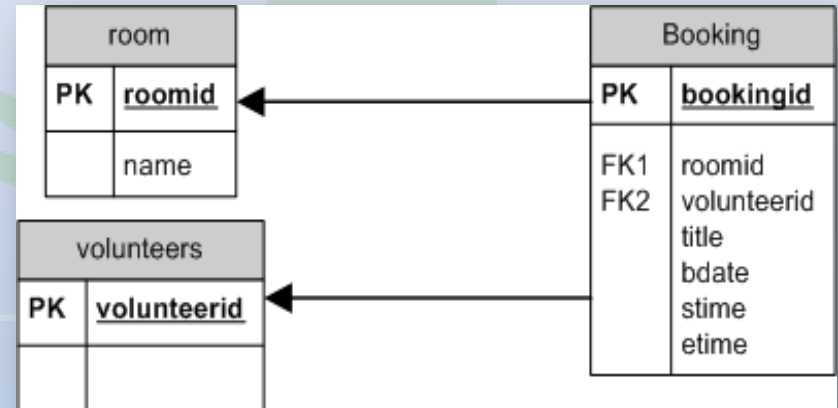



- Analysis problem

Spreadsheet
40 fields

- Understand
- Interpret
- Sort

- Features

- Add/Edit fundraisers
- Search by any fields
- Advanced search
- Notification

Fundraising Section
6 subsections

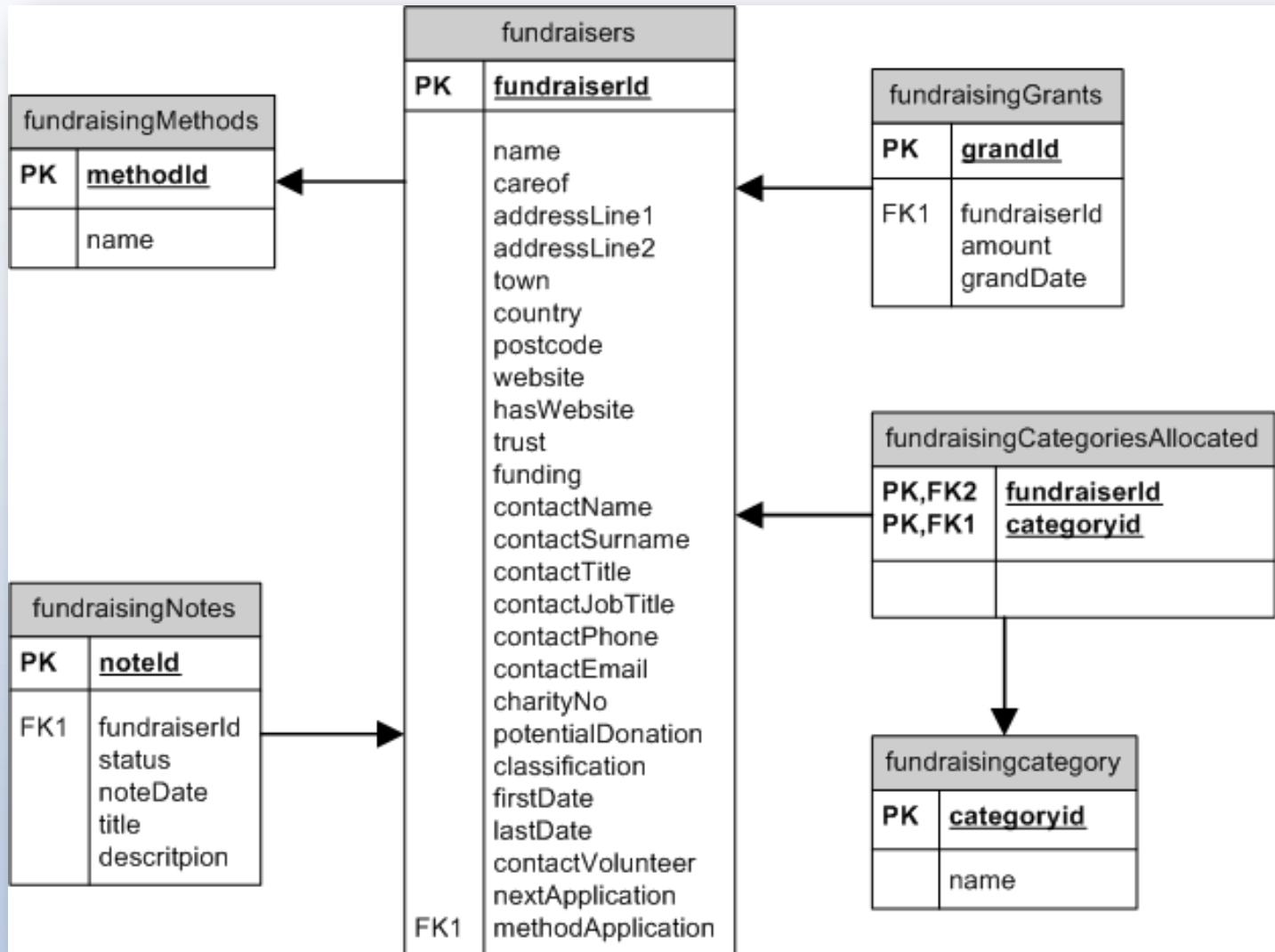

Minor Improvements

- ID Cards
 - Alphabetical order
 - New address
 - ID number printed
- More information stored about:
 - Homes
 - Service Users
 - Volunteers
- PrintShop allows storing and retrieval of forms

Conclusion

- Fulfilled all the improvements requested on existing functionality
- Implemented the majority of the extensions
- Received positive feedback
- Future Work
 - Dynamic Forms
 - Extend Access Control

Questions?



Thank You For Listening