

Frank



Einar



Tobias



Dave



UPSCALE

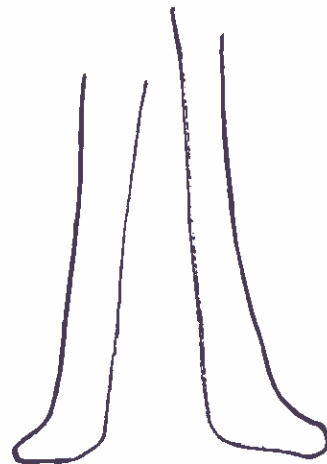

Sophia



Nobuko

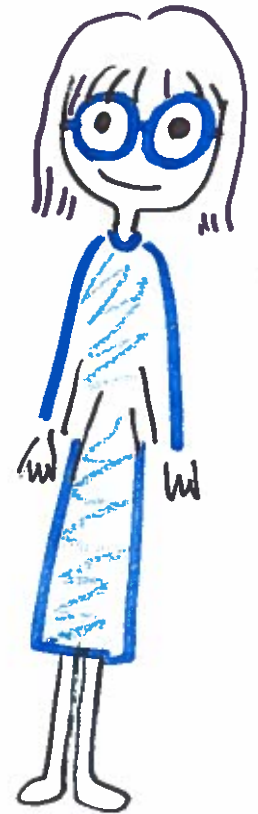

UpScale Project (FP7)

- CWI, Imperial College London, University of Oslo and Uppsala University
- Study how an OO PL can support the development of applications that seamlessly scale to the available parallelism of manycore chips.
- Take an actor-based concurrency model as a starting point, rather than multi-threading, and use types to "open up the actors" for further parallelism, keeping the amount of concurrency implicit in the language.
- Capability types, Ownership types, Session Types, etc.

An overview of
UpScale @ Imperial College London



Nobuko
Yoshida

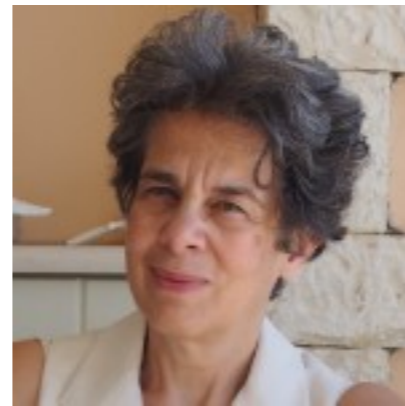

Sophia
Drossopoulou



Juliana
Franco

An Overview of UPSCALE @ OSLO

Shiji Bijo, Einar Broch Johnsen, Violet Ka I Pun, S. Lizeth Tapia Tarifa



$$\begin{aligned} R_1 &= R_2 = R_3 \\ R_2 &= R_3 = R_4 \\ \bar{C}R_1 &\xrightarrow{R_2=R_3} \bar{C}R_2 & \bar{C}R_2 &\xrightarrow{R_3=R_4} \bar{C}R_3 \\ \bar{C}R_1 &\xrightarrow{R_2=R_3} \bar{C}R_2 & \bar{C}R_2 &\xrightarrow{R_3=R_4} \bar{C}R_3 \end{aligned}$$



Nobuko Yoshida

Imperial College London

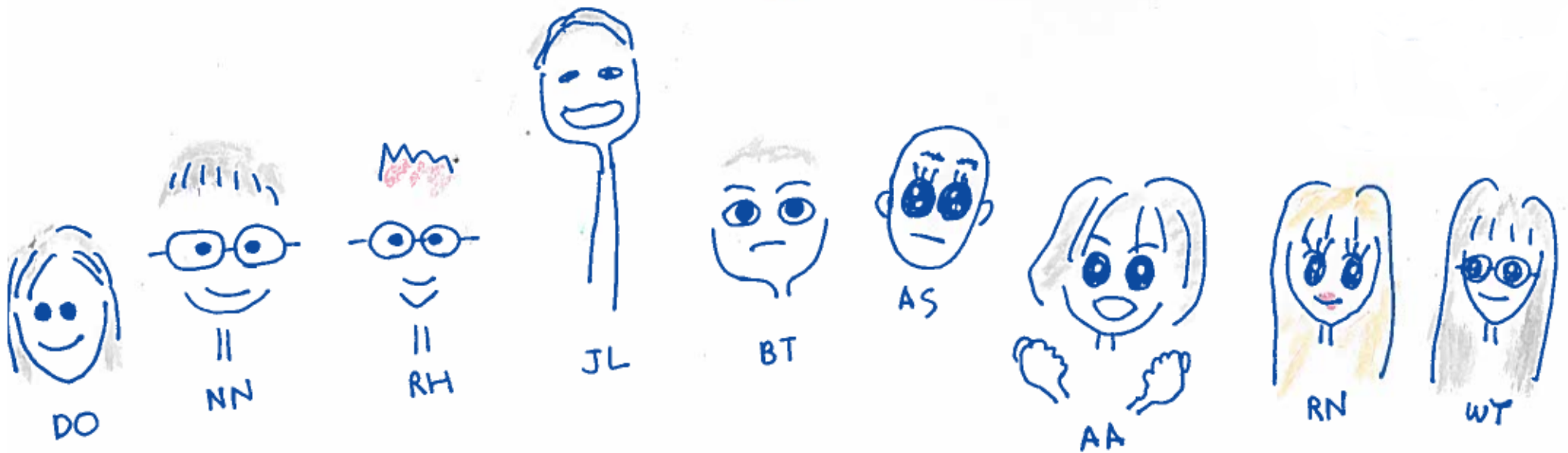

Mobility Reading Group

mrg.doc.ic.ac.uk

Selected Publications 2015/2016



- **[CC'16]** Nicholas Ng, NY: Static Deadlock Detection for Concurrent Go by Global Session Graph Synthesis.
- **[FASE'16]** Raymond Hu, NY: Hybrid Session Verification through Endpoint API Generation.
- **[TACAS'16]** Julien Lange, NY: Characteristic Formulae for Session Types.
- **[ESOP'16]** Dimitrios Kouzapas, Jorge A. Pérez, NY: On the Relative Expressiveness of Higher-Order Session Processes.
- **[POPL'16]** Dominic Orchard, NY: Effects as sessions, sessions as effects .
- **[FSTTCS'15]** Romain Demangeon, NY: On the Expressiveness of Multiparty Session Types.
- **[OOPSLA'15]** Hugo A. López, Eduardo R. B. Marques, Francisco Martins, Nicholas Ng, César Santos, Vasco Thudichum Vasconcelos, NY: Protocol-Based Verification of Message-Passing Parallel Programs .
- **[CONCUR'15]** Dimitrios Kouzapas, Jorge A. Pérez, NY: Characteristic Bisimulations for Higher-Order Session Processes .
- **[CONCUR'15]** Laura Bocchi, Julien Lange, NY: Meeting Deadlines Together.
- **[CONCUR'15]** Marco Carbone, Fabrizio Montesi, Carsten Schürmann, NY: Multiparty Session Types as Coherence Proofs.
- **[CC'15]** Nicholas Ng, Jose G.F. Coutinho, NY: Protocols by Default: Safe MPI Code Generation based on Session Types.
- **[PPoPP'15]** Tiago Cogumbreiro, Raymond Hu, Francisco Martins, NY: Dynamic deadlock verification for general barrier synchronisation.
- **[POPL'15]** Julien Lange, Emilio Tuosto, NY: From communicating machines to graphical choreographies.

Selected Publications 2015/2016



- **[CC'16]** Nicholas Ng, NY: Static Deadlock Detection for Concurrent Go by Global Session Graph Synthesis.
- **[FASE'16]** Raymond Hu, NY: Hybrid Session Verification through Endpoint API Generation.
- **[TACAS'16]** Julien Lange, NY: Characteristic Formulae for Session Types.
- **[ESOP'16]** Dimitrios Kouzapas, Jorge A. Pérez, NY: On the Relative Expressiveness of Higher-Order Session Processes.
- **[POPL'16]** Dominic Orchard, NY: Effects as sessions, sessions as effects .
- **[FSTTCS'15]** Romain Demangeon, NY: On the Expressiveness of Multiparty Session Types.
- **[OOPSLA'15]** Hugo A. López, Eduardo R. B. Marques, Francisco Martins, Nicholas Ng, César Santos, Vasco Thudichum Vasconcelos, NY: Protocol-Based Verification of Message-Passing Parallel Programs .
- **[CONCUR'15]** Dimitrios Kouzapas, Jorge A. Pérez, NY: Characteristic Bisimulations for Higher-Order Session Processes .
- **[CONCUR'15]** Laura Bocchi, Julien Lange, Nobuko Yoshida: Meeting Deadlines Together.
- **[CONCUR'15]** Marco Carbone, Fabrizio Montesi, Carsten Schürmann, NY: Multiparty Session Types as Coherence Proofs.
- **[CC'15]** Nicholas Ng, Jose G.F. Coutinho, NY: Protocols by Default: Safe MPI Code Generation based on Session Types.
- **[PPoPP'15]** Tiago Cogumbreiro, Raymond Hu, Francisco Martins, NY: Dynamic deadlock verification for general barrier synchronisation.
- **[POPL'15]** Julien Lange, Emilio Tuosto, NY: From communicating machines to graphical choreographies.

Ocean Observatories Initiative

- A NSF project (400M\$, 5 Years) to build a cyberinfrastructure for observing oceans around US and beyond.
- Real-time sensor data constantly coming from both off-shore and on-shore (e.g. buoys, submarines, under-water cameras, satellites), transmitted via high-speed networks.

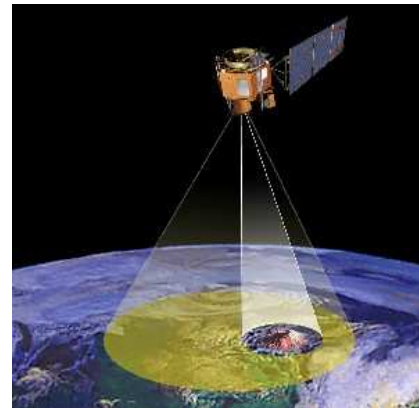
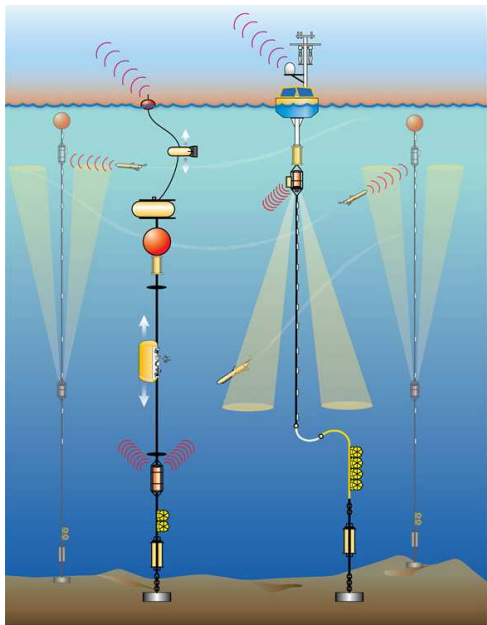

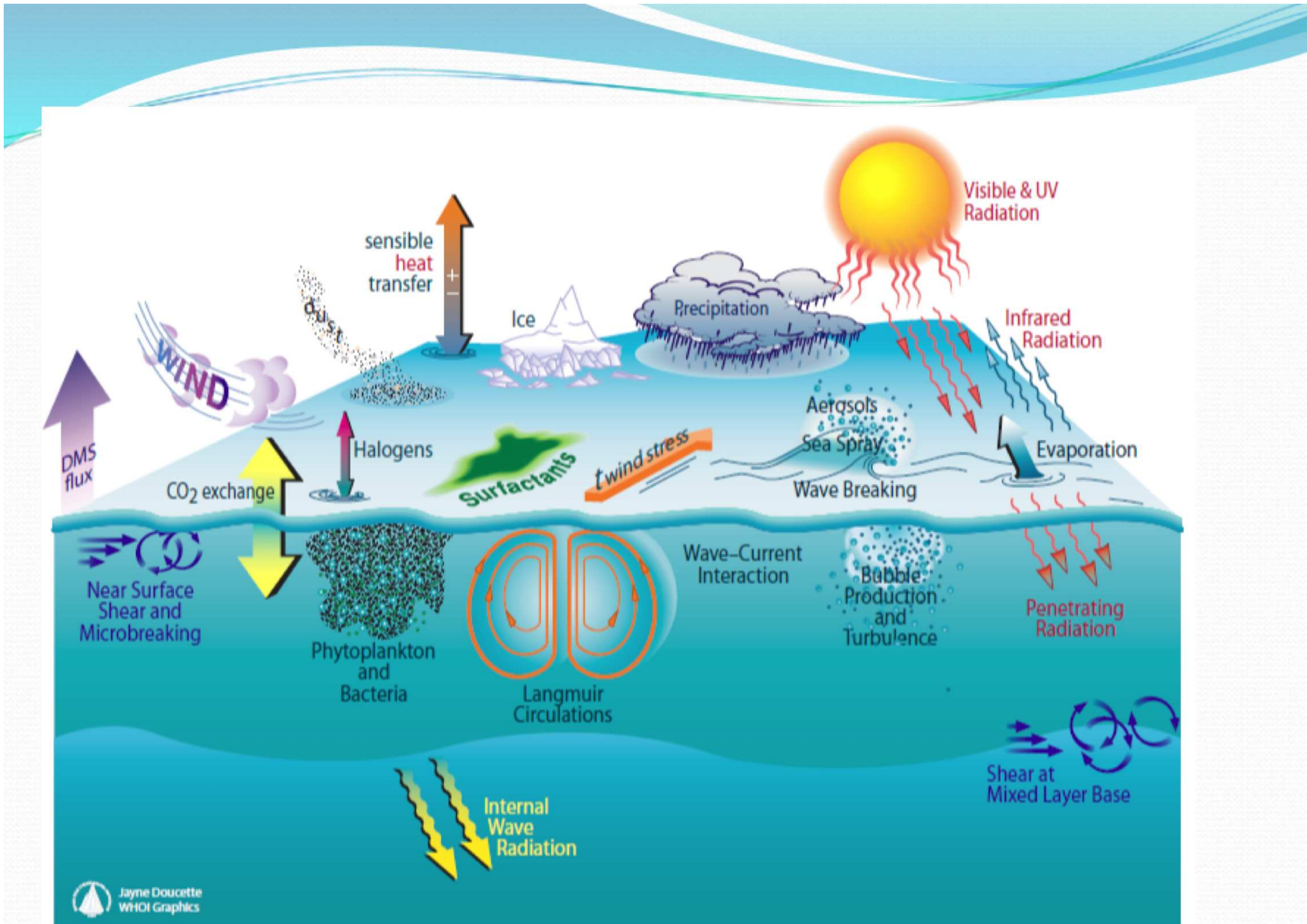

Ocean Observatories Initiative

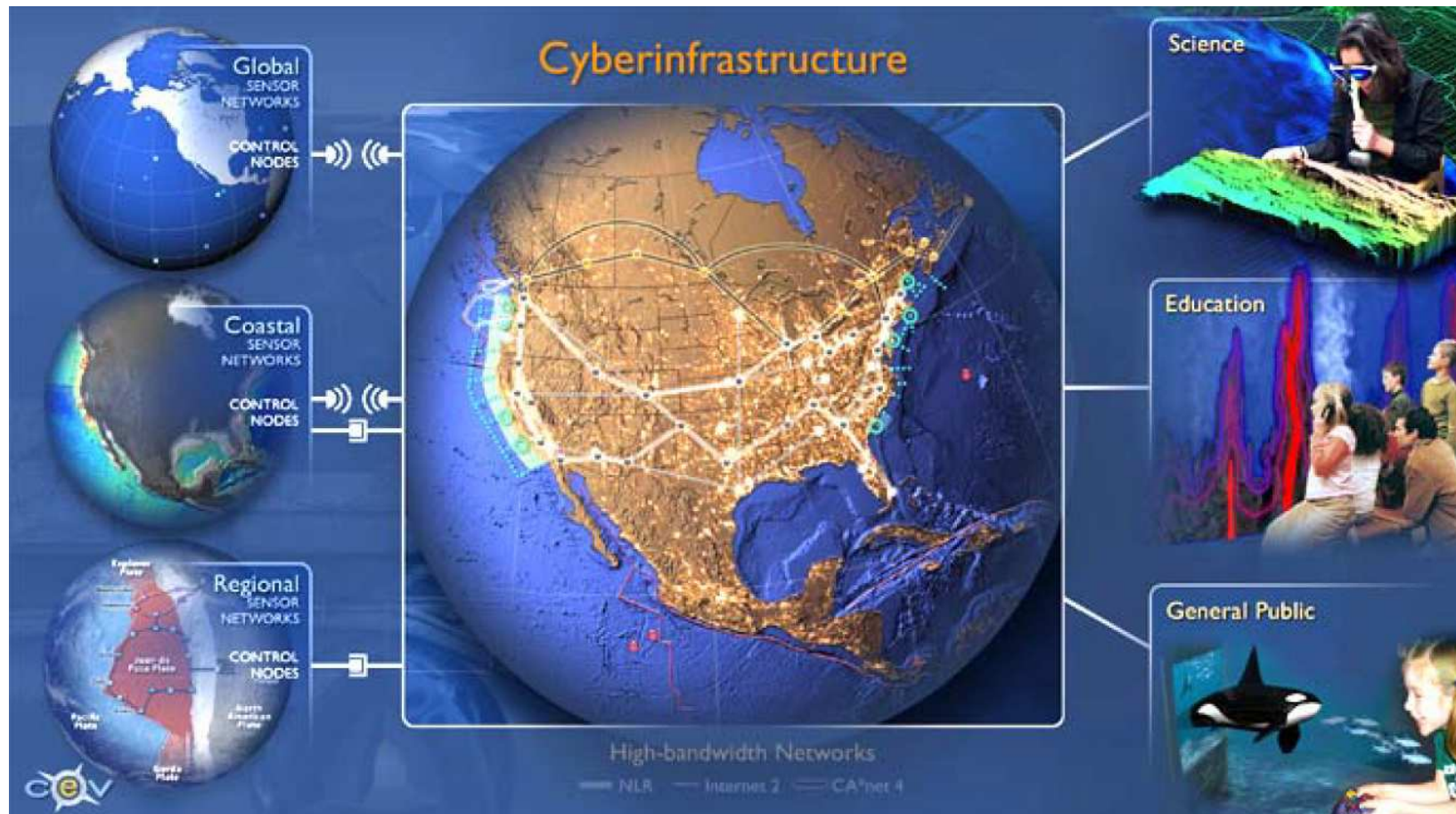

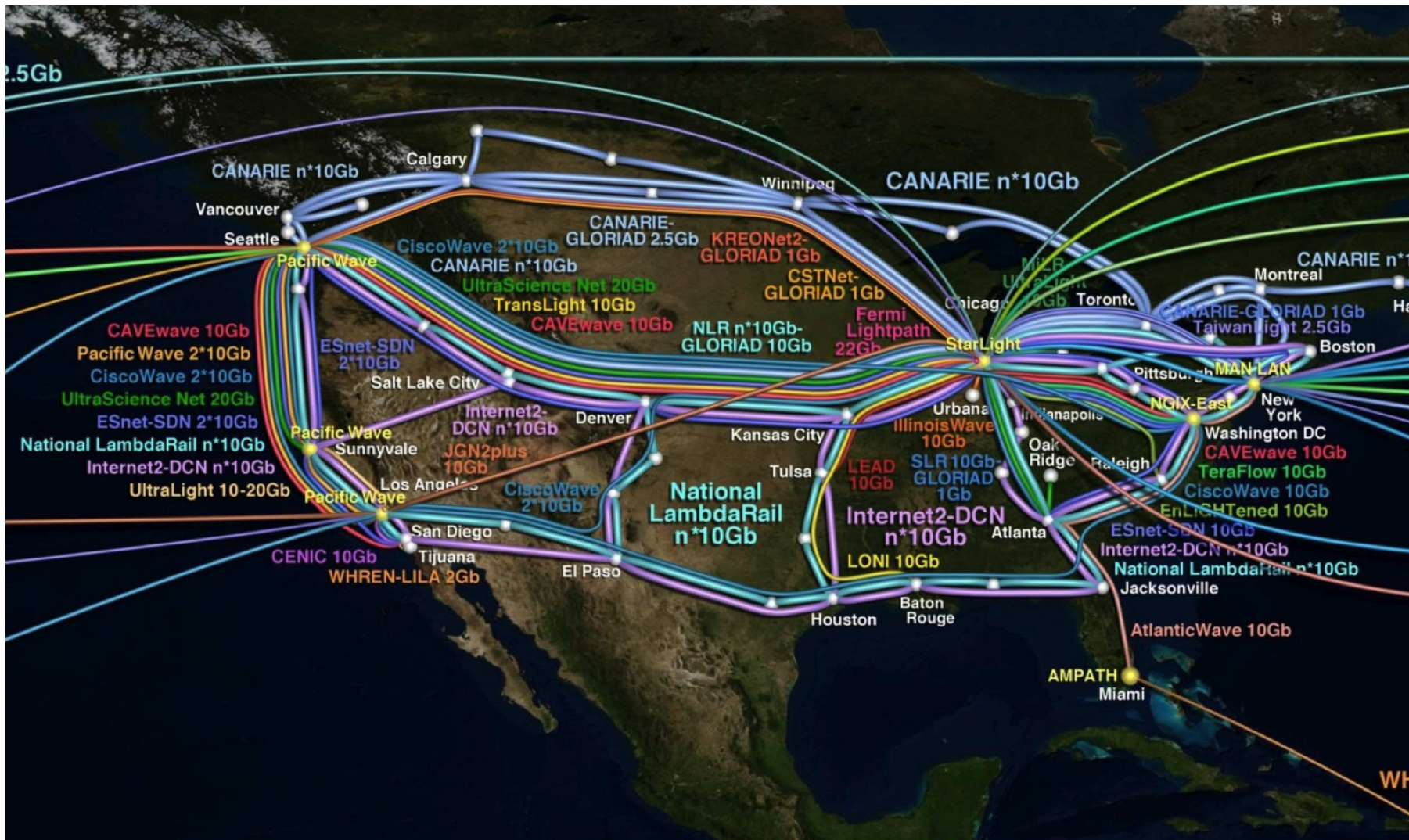

Ocean Observatories Initiative

Challenges

- The need to specify, catalogue, program, implement and manage *multiparty message passing protocols*.
- Communication assurance
 - Correct message ordering and synchronisation
 - Deadlock-freedom, progress and liveness
 - Dynamic message monitoring and recovery
 - Logical constraints on message values
- Shared and used over a long-term period (e.g. 30 years in OOI).

<http://scribble.doc.ic.ac.uk:55000/>



```
1 module examples;
2
3 global protocol HelloWorld(role Me, role World) {
4     hello() from Me to World;
5     choice at World {
6         goodMorning() from World to Me;
7     } or {
8         goodAfternoon() from World to Me;
9     }
10 }
11
```

Hello World ▾

Check

Protocol:

Role:

Project

Generate Graph













Dynamic Monitoring

[RV'13, COORDINATION'14, FMSSD'15]

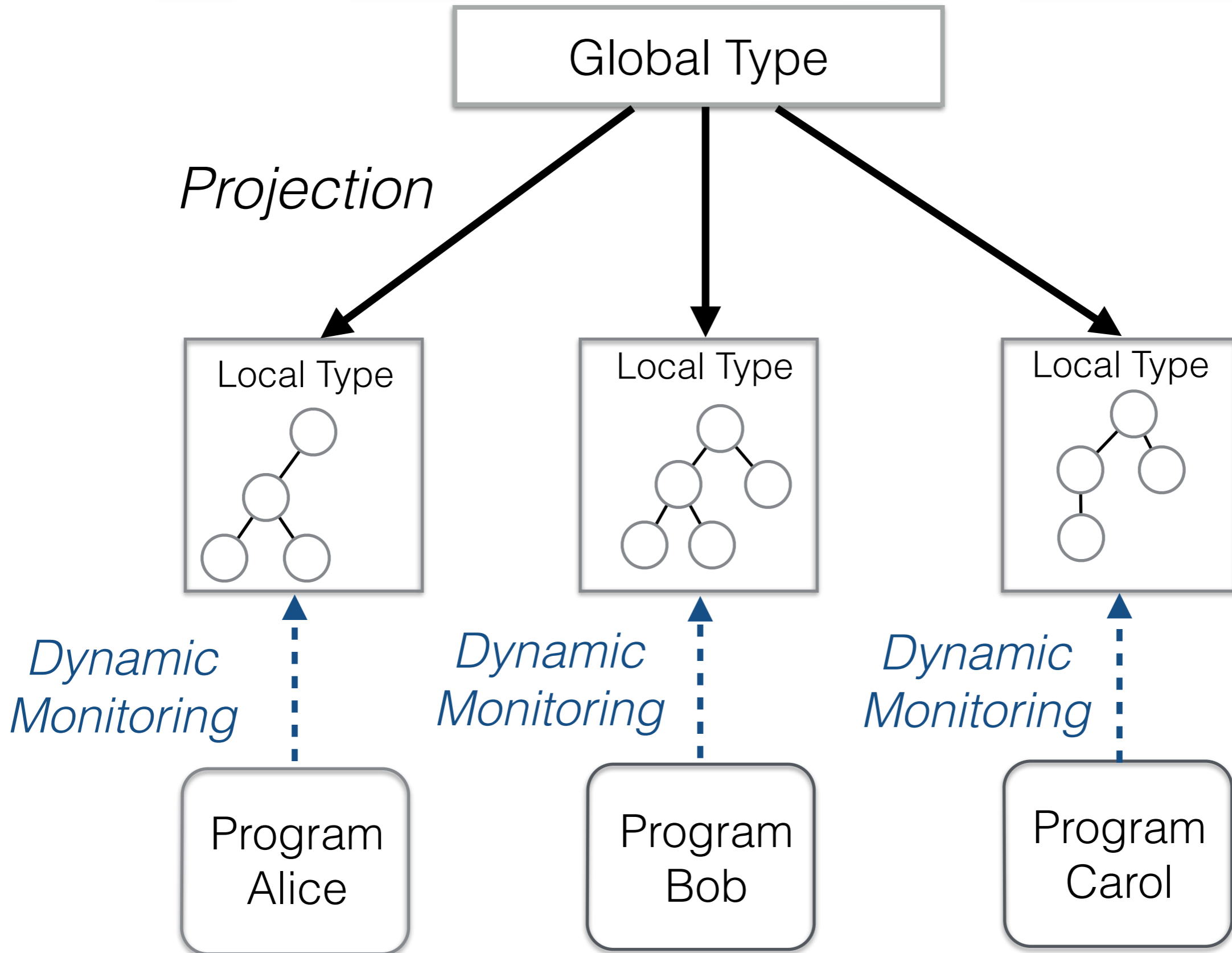

OOI agent negotiation 1/5

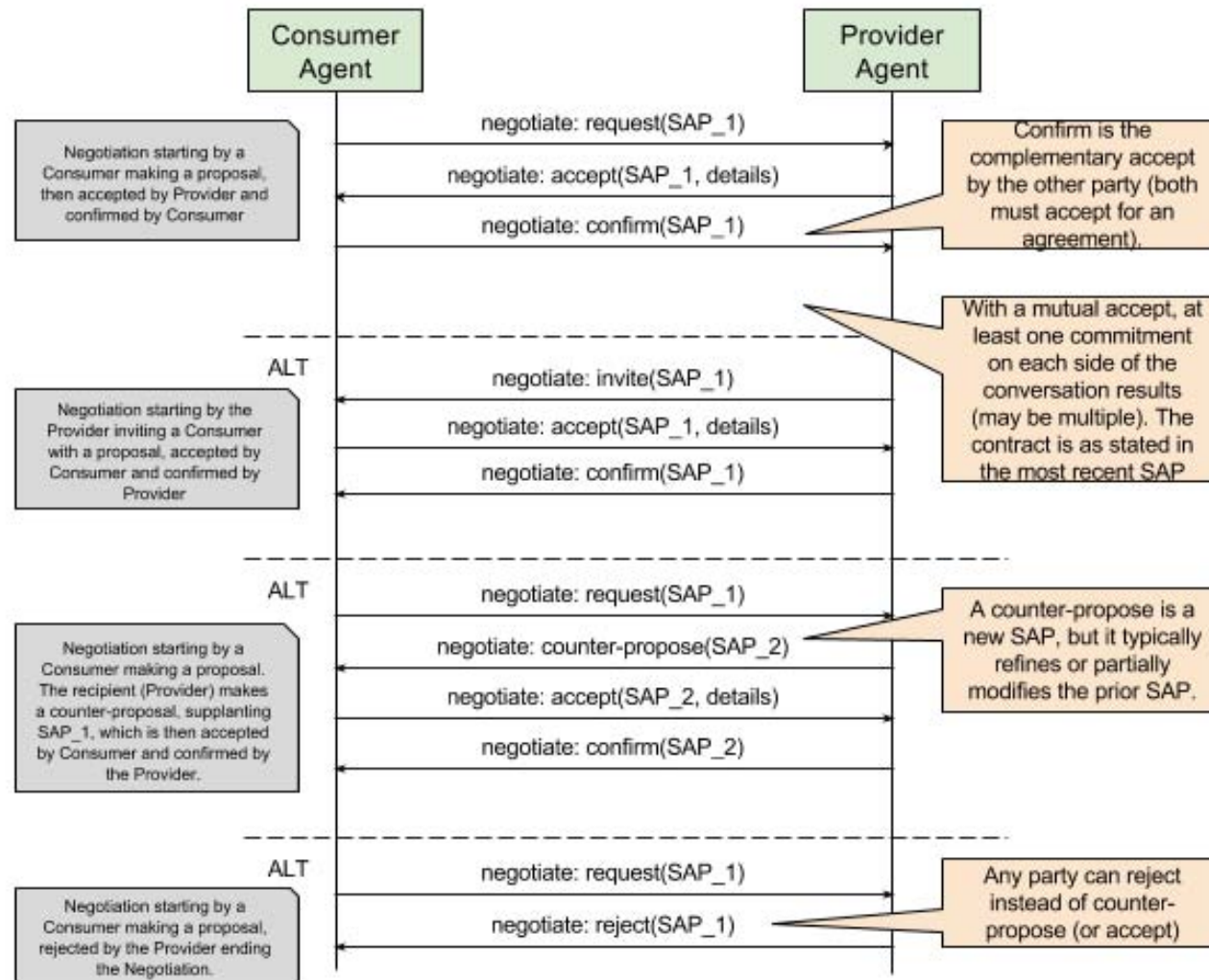

- ▶ <https://confluence.oceanobservatories.org/display/syseng/CIAD+COI+OV+Negotiate+Protocol>

OOI agent negotiation 2/5

```
type <yml> "SAPDoc1" from "SAPDoc1.yml" as SAP;
```

```
global protocol Negotiate(role Consumer as C, role Producer as P) {
```

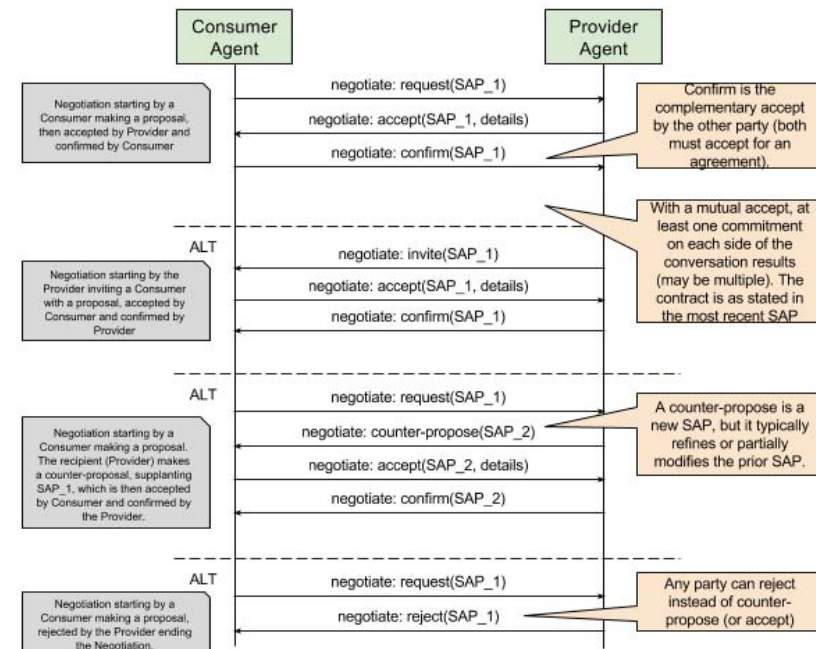

```
}
```

OOI agent negotiation 3/5 (choice)

```
type <yml> "SAPDoc1" from "SAPDoc1.yml" as SAP;
```

```
global protocol Negotiate(role Consumer as C, role Producer as P) {  
  propose(SAP) from C to P;
```

```
  choice at P {  
    accept() from P to C;  
    confirm() from C to P;  
  } or {  
    reject() from P to C;  
  } or {  
    propose(SAP) from P to C;
```

```
  } }  
}
```

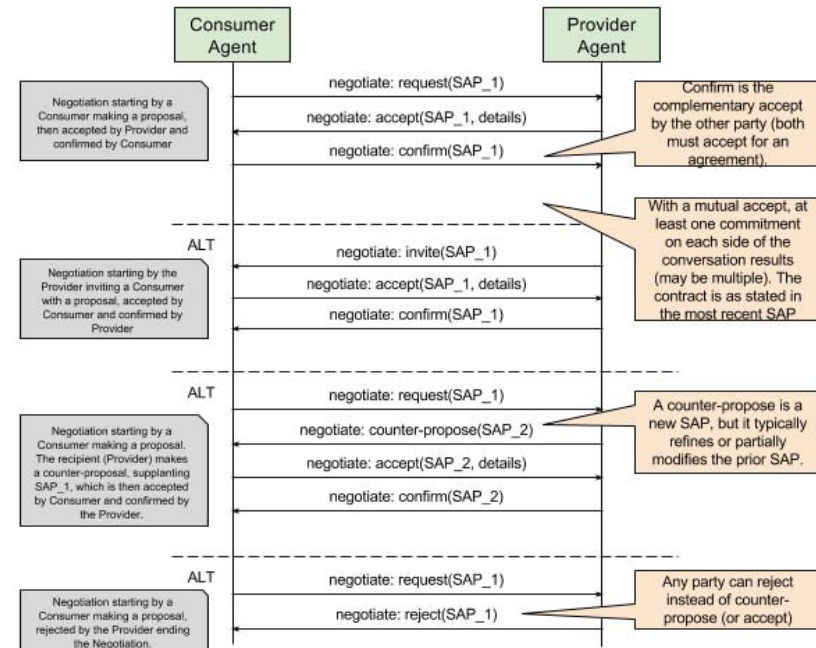

OOI agent negotiation 4/5

```
type <yml> "SAPDoc1" from "SAPDoc1.yml" as SAP;
```

```
global protocol Negotiate(role Consumer as C, role Producer as P) {
  propose(SAP) from C to P;
```

```
  choice at P {
    accept() from P to C;
    confirm() from C to P;
  } or {
    reject() from P to C;
  } or {
    propose(SAP) from P to C;
    choice at C {
      accept() from C to P;
      confirm() from P to C;
    } or {
      reject() from C to P;
    } or {
      propose(SAP) from C to P;
    }
  }
}
```

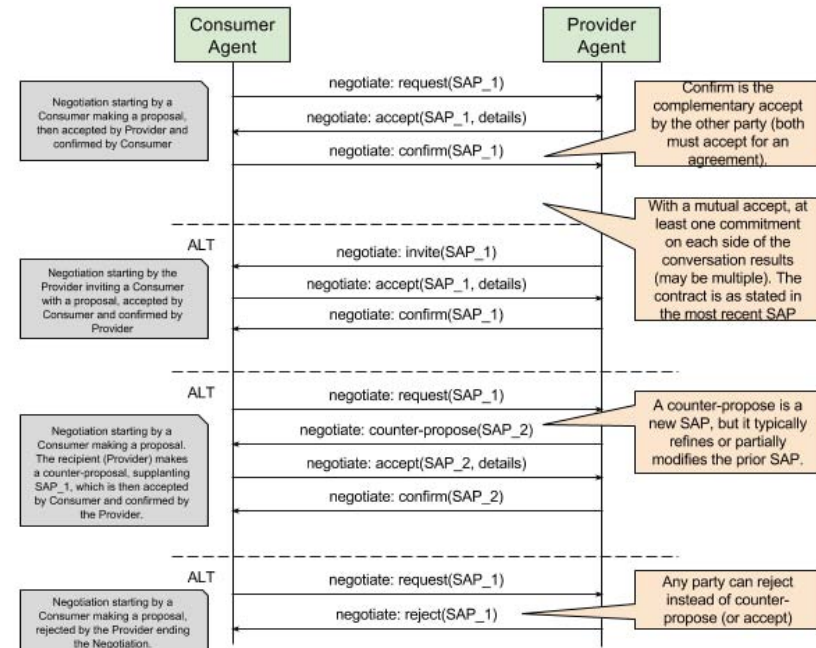

OOI agent negotiation 5/5 (recursion)

```
type <yml> "SAPDoc1" from "SAPDoc1.yml" as SAP;
```

```
global protocol Negotiate(role Consumer as C, role Producer as P) {
  propose(SAP) from C to P;
  rec X {
    choice at P {
      accept() from P to C;
      confirm() from C to P;
    } or {
      reject() from P to C;
    } or {
      propose(SAP) from P to C;
      choice at C {
        accept() from C to P;
        confirm() from P to C;
      } or {
        reject() from C to P;
      } or {
        propose(SAP) from C to P;
        continue X;
      }
    }
  }
}
```

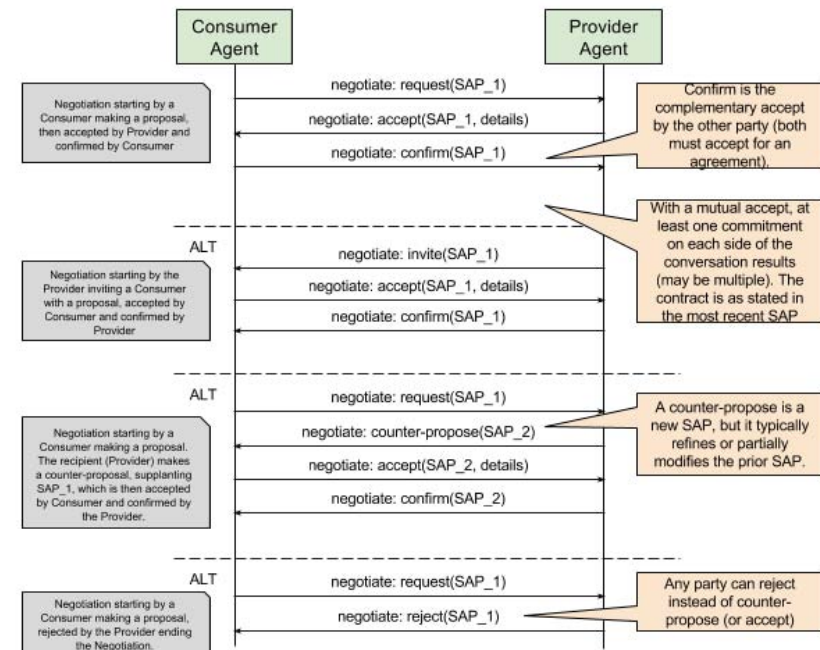

Local protocol projection (Negotiation Consumer)

```
// Global
propose(SAP) from C to P;
rec START {
  choice at P {
    accept() from P to C;
    confirm() from C to P;
  } or {
    reject() from P to C;
  } or {
    propose(SAP) from P to C;
    choice at C {
      accept() from C to P;
      confirm() from P to C;
    } or {
      reject() from C to P;
    } or {
      propose(SAP) from C to P;
      continue START;
    }
  }
}
```

```
// Projection for Consumer
propose(SAP) to P;
rec START {
  choice at P {
    accept() from P;
    confirm() to P;
  } or {
    reject() from P;
  } or {
    propose(SAP) from P;
    choice at C {
      accept() to P;
      confirm() from P;
    } or {
      reject() to P;
    } or {
      propose(SAP) to P;
      continue START;
    }
  }
}
```

FSM generation (Negotiation Consumer)

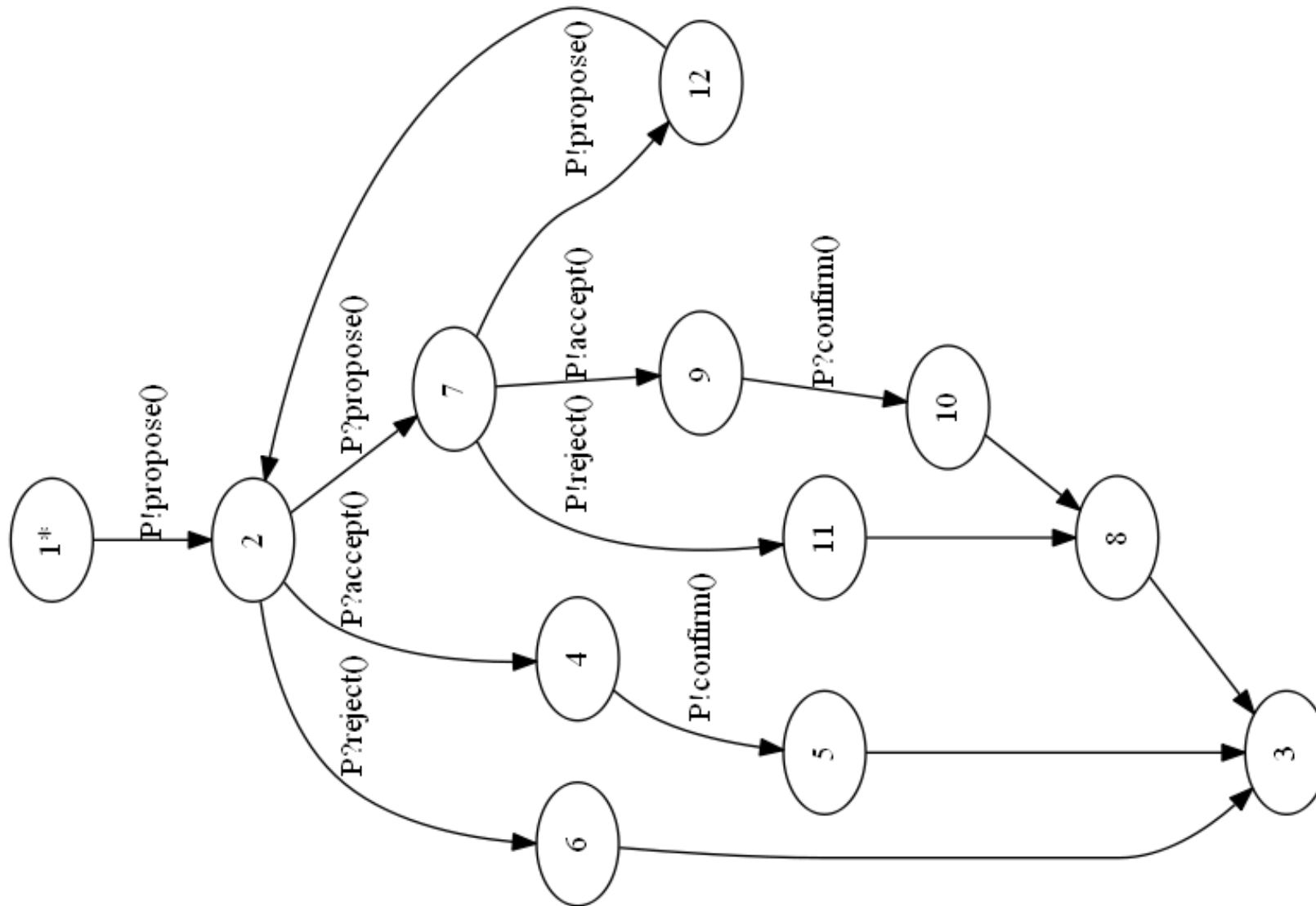

Scribble Community

- ▶ **Webpage:**

- ▶ www.scribble.org

- ▶ **GitHub:**

- ▶ <https://github.com/scribble>

- ▶ **Tutorial:**

- ▶ www.doc.ic.ac.uk/~rhu/scribble/tutorial.html

- ▶ **Specification (0.3)**

- ▶ www.doc.ic.ac.uk/~rhu/scribble/langref.html



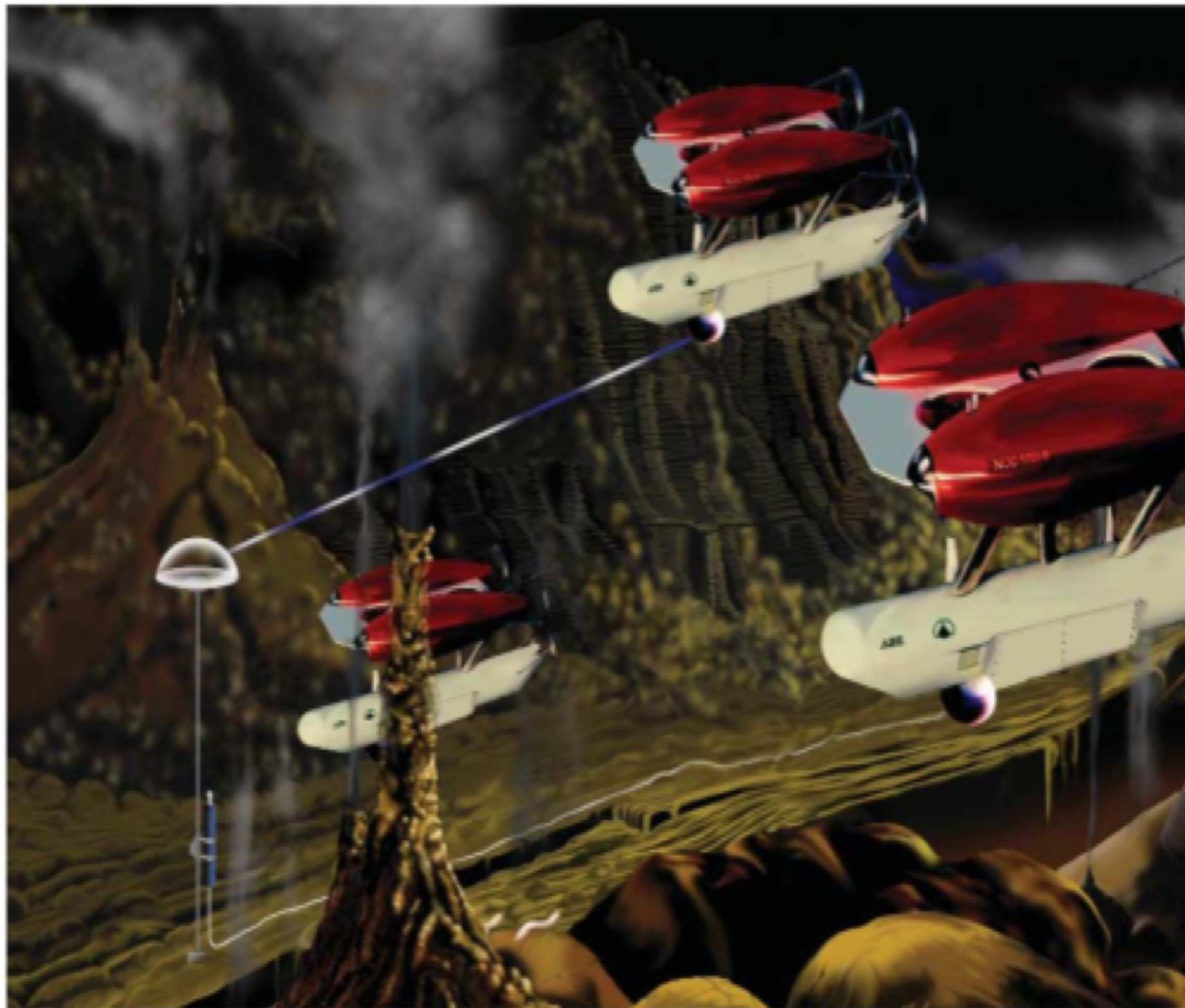

Figure 5: A coordinated set of autonomous underwater vehicles



Figure 3: Observatory comprised of ships, aircraft and autonomous vehicles linked to assimilation modeling capabilities on shore



SEARCH

RESOURCES

- All Resources
- Data Products
- Observatories
- Platforms
- Instruments

Welcome to Release 2 of the Ocean Observatories Initiative Observatory (OOI). You already have access to many OOI features and real-time data. Just click on something that looks interesting on this page to start using the OOI as our Guest.

For personalized services, such as setting up notifications and preserving settings for your next visit, create a free account by clicking on "Create Account" at the top of the page.



National Science Foundation working with Consortium for Ocean Leadership

Funding for the Ocean Observatories Initiative is provided by the National Science Foundation through a Cooperative Agreement with the Consortium for Ocean Leadership. The OOI Program Implementing Organizations are funded through sub-awards from the Consortium for Ocean Leadership.

Location

CURRENT LOCATION

FILTER



DATA LEGEND

- Temperature
- Salinity
- Oxygen
- Density
- Currents
- Sea Surface Height (SSH)
- Chlorophyll
- Turbidity
- pH
- Seismology
- Other

REQUENCY

- 1 Hour
- 2 hours
- 3 hours
- 5 hours
- 8 hours
- 12 hours
- 18 hours
- 24 hours
- 48 Hours
- 72 Hours

RECENT UPDATES

NAME	DATE	TYPE	EVENT	DESCRIPTION	NOTE
01 m Oregon Coast North Salinity	2012-01-10 23:55:55	Type	Event	Description goes here	Note goes here
01 m California South 100m pH	2012-01-10 23:55:55	Type	Event	Description goes here	Note goes here
01 m California South salinity	2012-01-10 23:55:55	Type	Event	Description goes here	Note goes here
03 m Oregon North Turbidity	2012-01-10 23:55:55	Type	Event	Description goes here	Note goes here
05 m Oregon South Temperature	2012-01-10 23:55:55	Type	Event	Description goes here	Note goes here
20 m Oregon Coast Currents	2012-01-10 23:55:55	Type	Event	Description goes here	Note goes here
01 h California South Seismology	2012-01-10 23:55:55	Type	Event	Description goes here	Note goes here
01 h Oregon Coast South 1000m Ox	2012-01-10 23:55:55	Type	Event	Description goes here	Note goes here
02 h California Coast Seismology	2012-01-10 23:55:55	Type	Event	Description goes here	Note goes here
04 h California North Seismology	2012-01-10 23:55:55	Type	Event	Description goes here	Note goes here

Dashboard

RECENT IMAGES

- Glider**
Last Modified: 2011-06-15
Last Viewed: 2011-12-15
Last Updated: 2011-12-30, 13.24
- Gorgonian Coral**
Last Modified: 2011-06-15
Last Viewed: 2011-12-15
Last Updated: 2011-12-30, 13.24
- Acoustic Release**
Last Modified: 2011-06-15
Last Viewed: 2011-12-15
Last Updated: 2011-12-30, 13.24

POPULAR RESOURCES

- SeaBird CDT**
Last Modified: 2011-06-15
Last Viewed: 2011-12-15
Last Updated: 2011-12-30, 13.24
- Marine caption**
Last Modified: 2011-06-15
Last Viewed: 2011-12-15
Last Updated: 2011-12-30, 13.24
- Surface Buoy**
Last Modified: 2011-06-15
Last Viewed: 2011-12-15
Last Updated: 2011-12-30, 13.24

UNUSUAL EVENTS

- Oregon Coast Wave Height**
Last Modified: 2011-06-15
Last Viewed: 2011-12-15
Last Updated: 2011-12-30, 13.24
- Water Surface Elevation**
Last Modified: 2011-06-15
Last Viewed: 2011-12-15
Last Updated: 2011-12-30, 13.24

Applications

OOI Governance

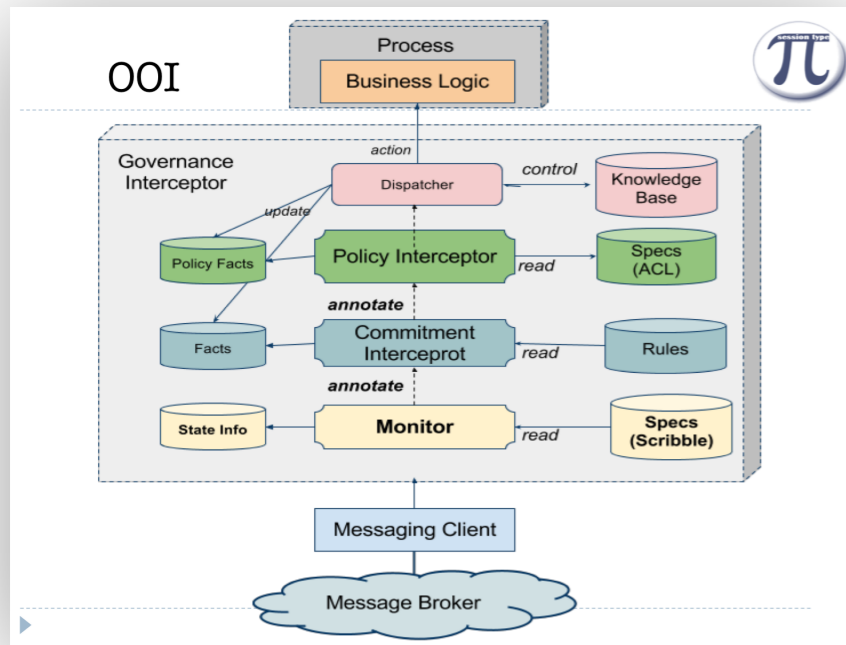

ZDLC: Process Modeling

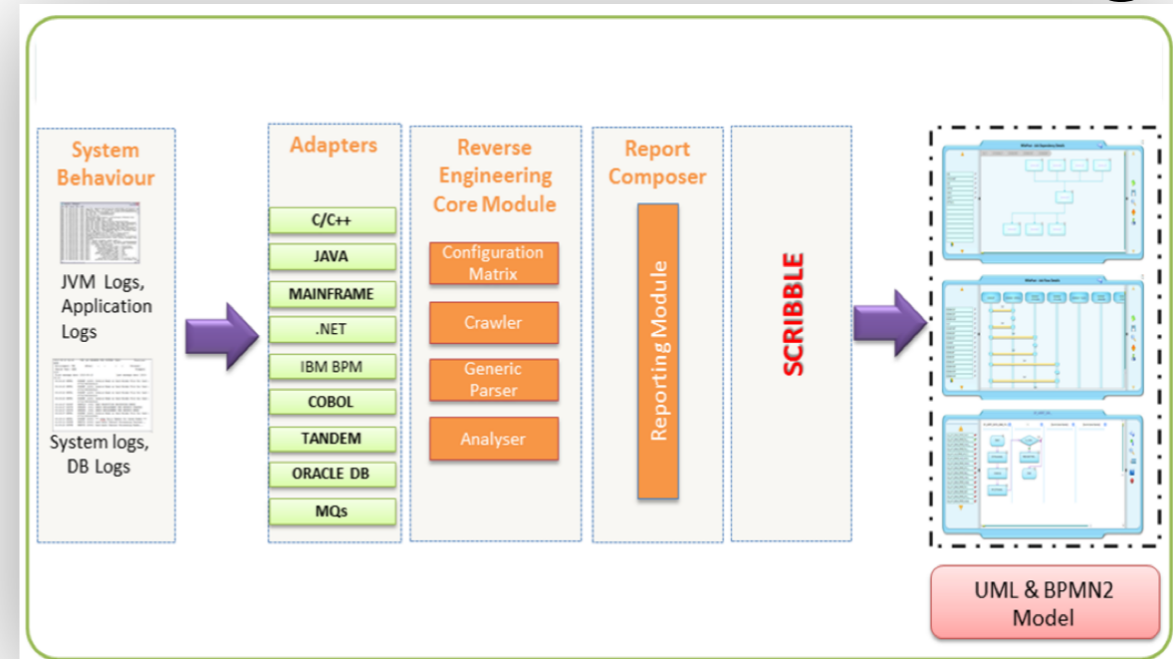

Protocol Verification

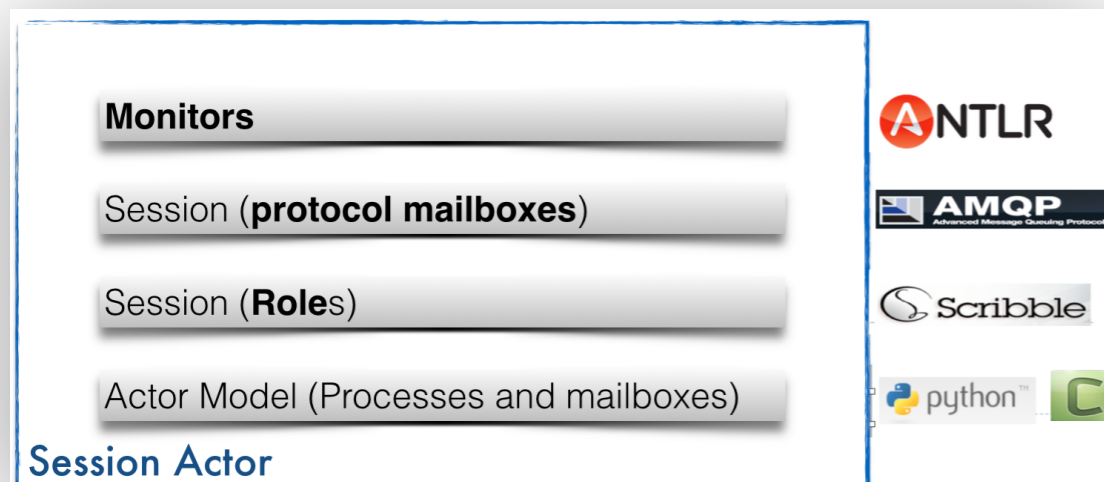

MPI code generations

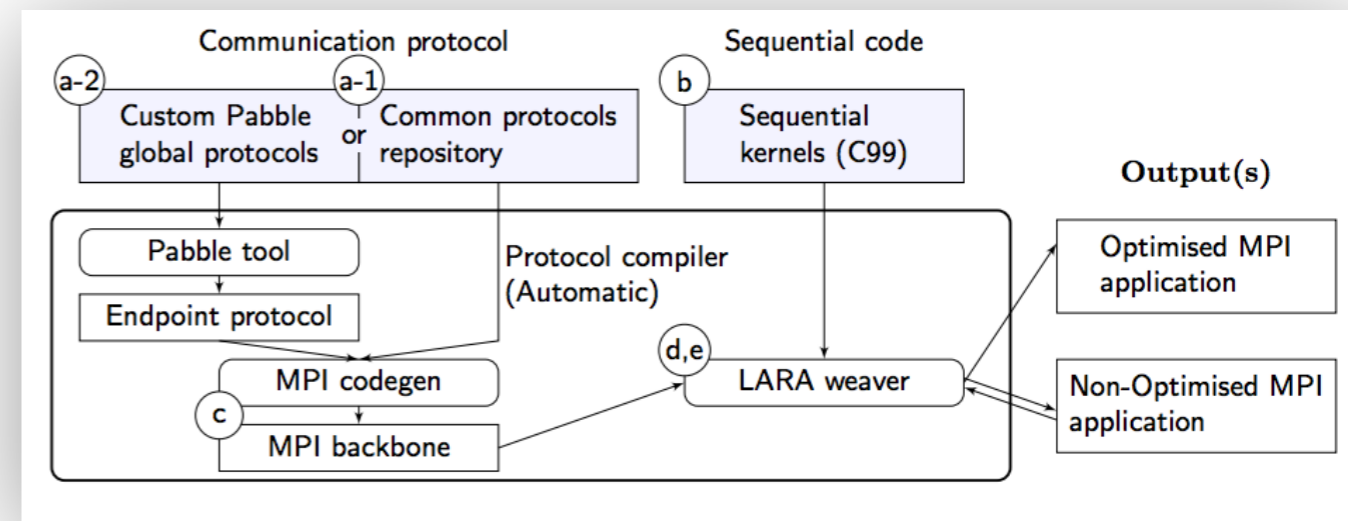

Dynamic Monitoring

[RV'13, COORDINATION'14, FMSSD'15]

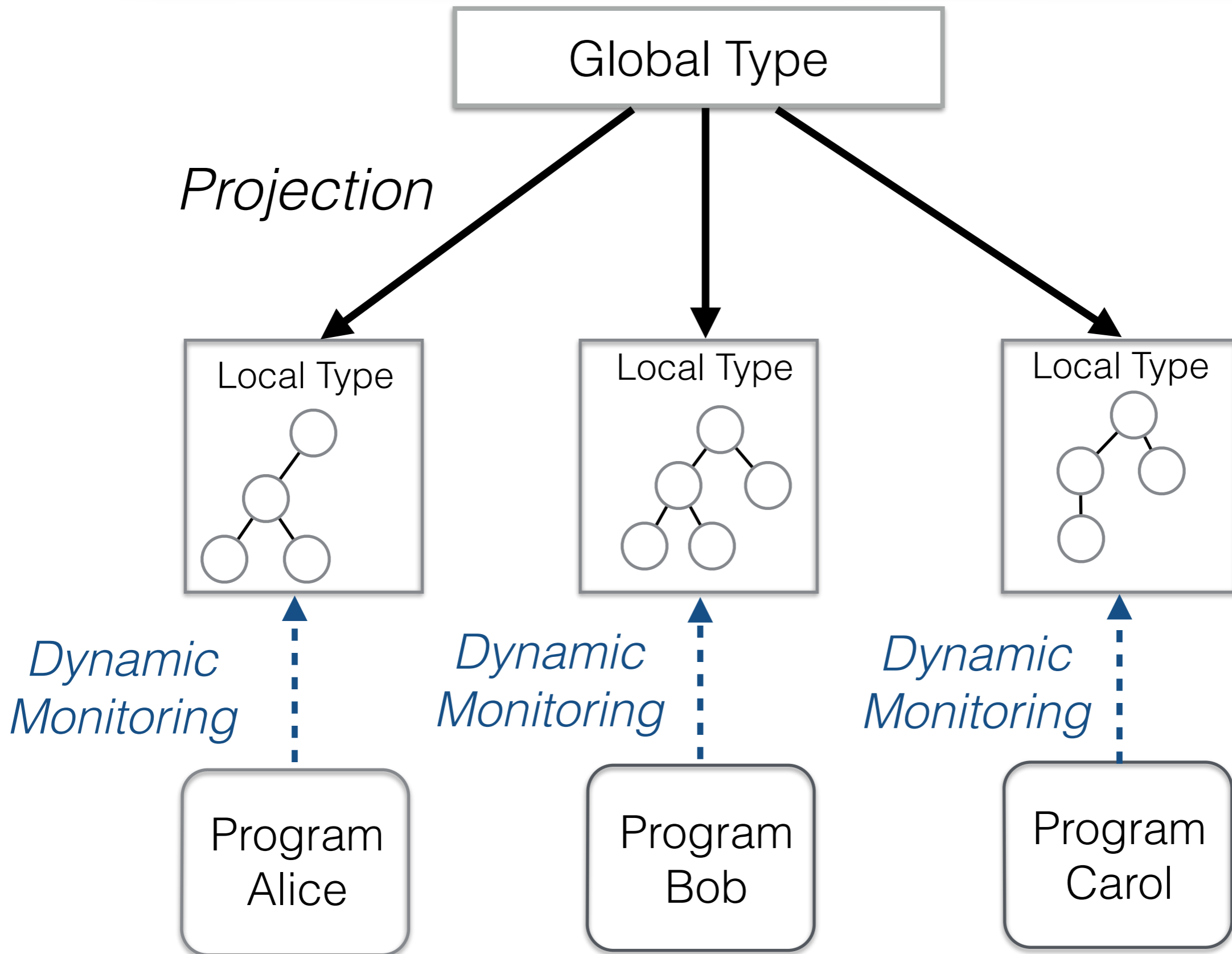

Type Checking [OOPSLA'15, POPL'16]

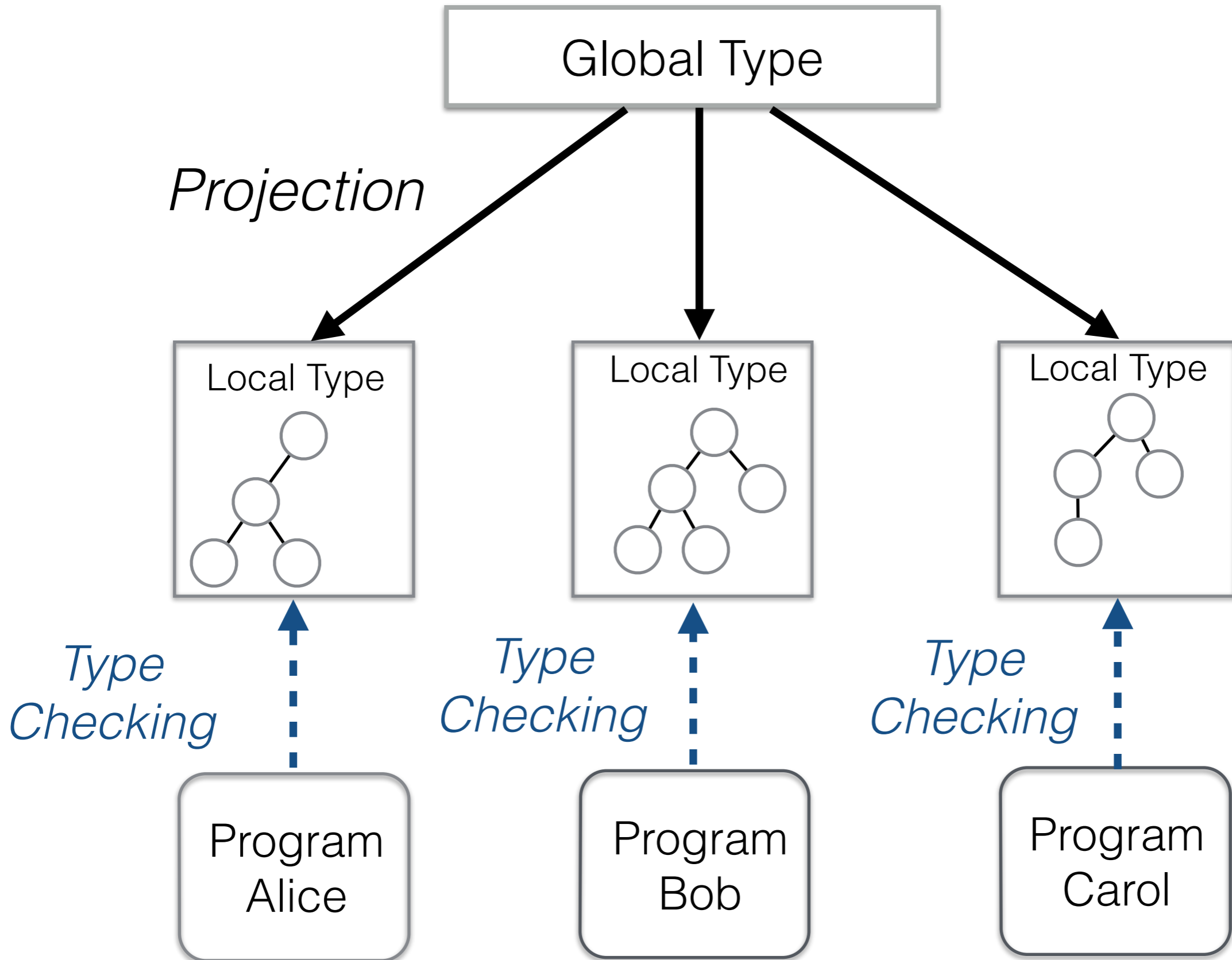

Code Generation [CC'15, FASE'16]

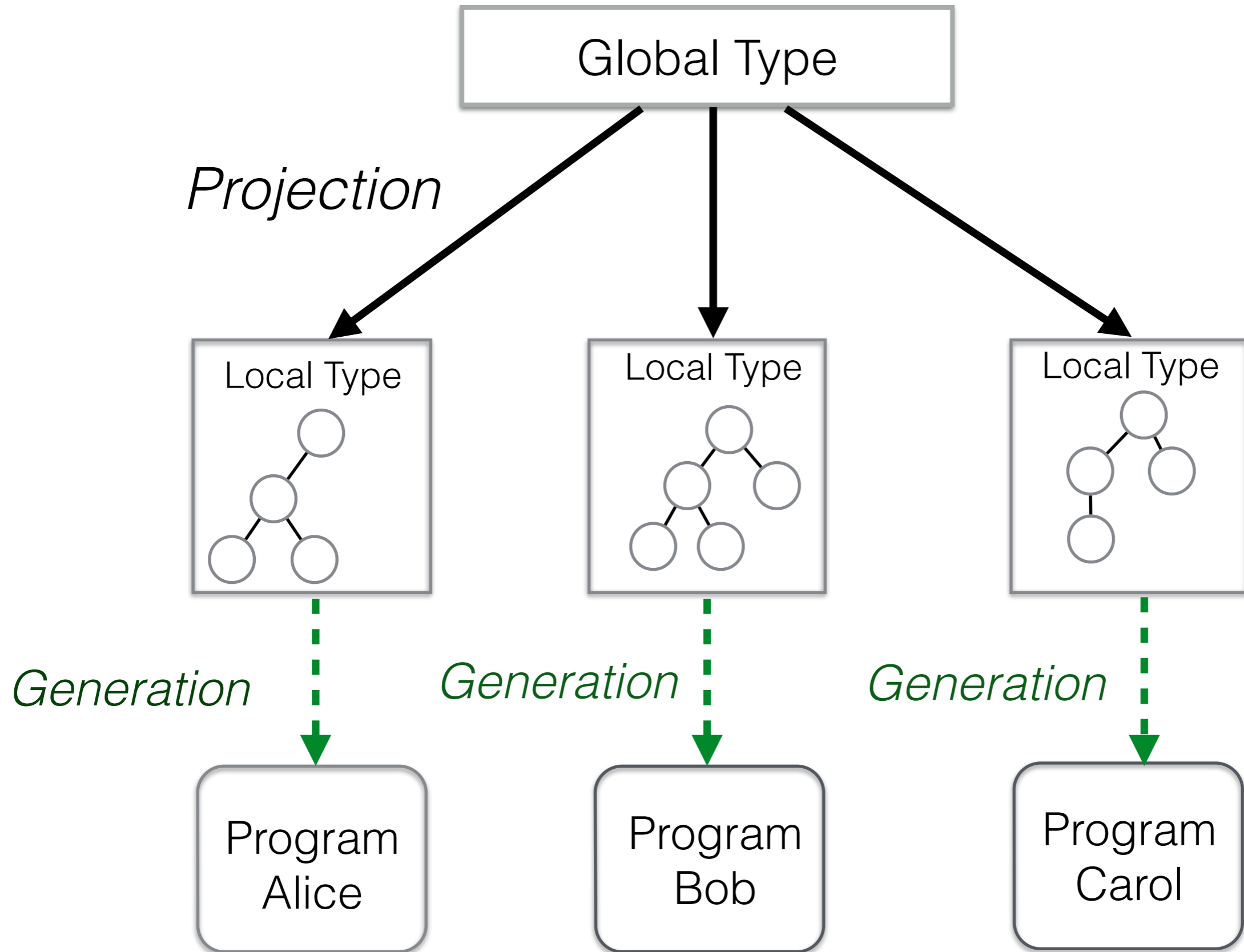

Synthesis

[ICALP'13, POPL'15, CONCUR'15, TACAS'16, CC'16]

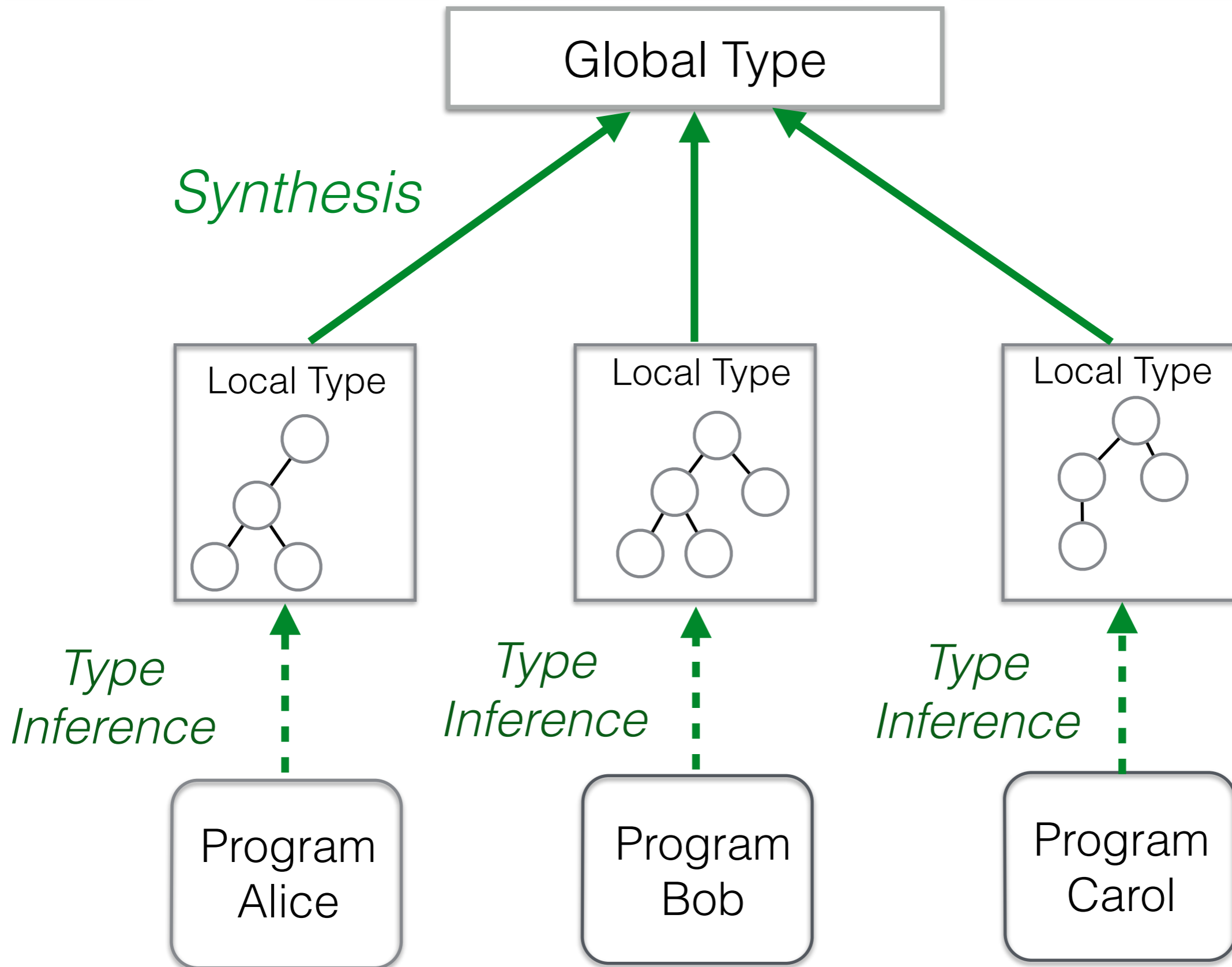

<http://www.zdlc.co/faq/>



[Home](#) [ZDLC Solutions](#) [FAQ](#) [Resources](#) [Events](#) [Blog](#) [Contact](#) [Partners](#) [Cognizant](#)



Zero Deviation Life Cycle Platform

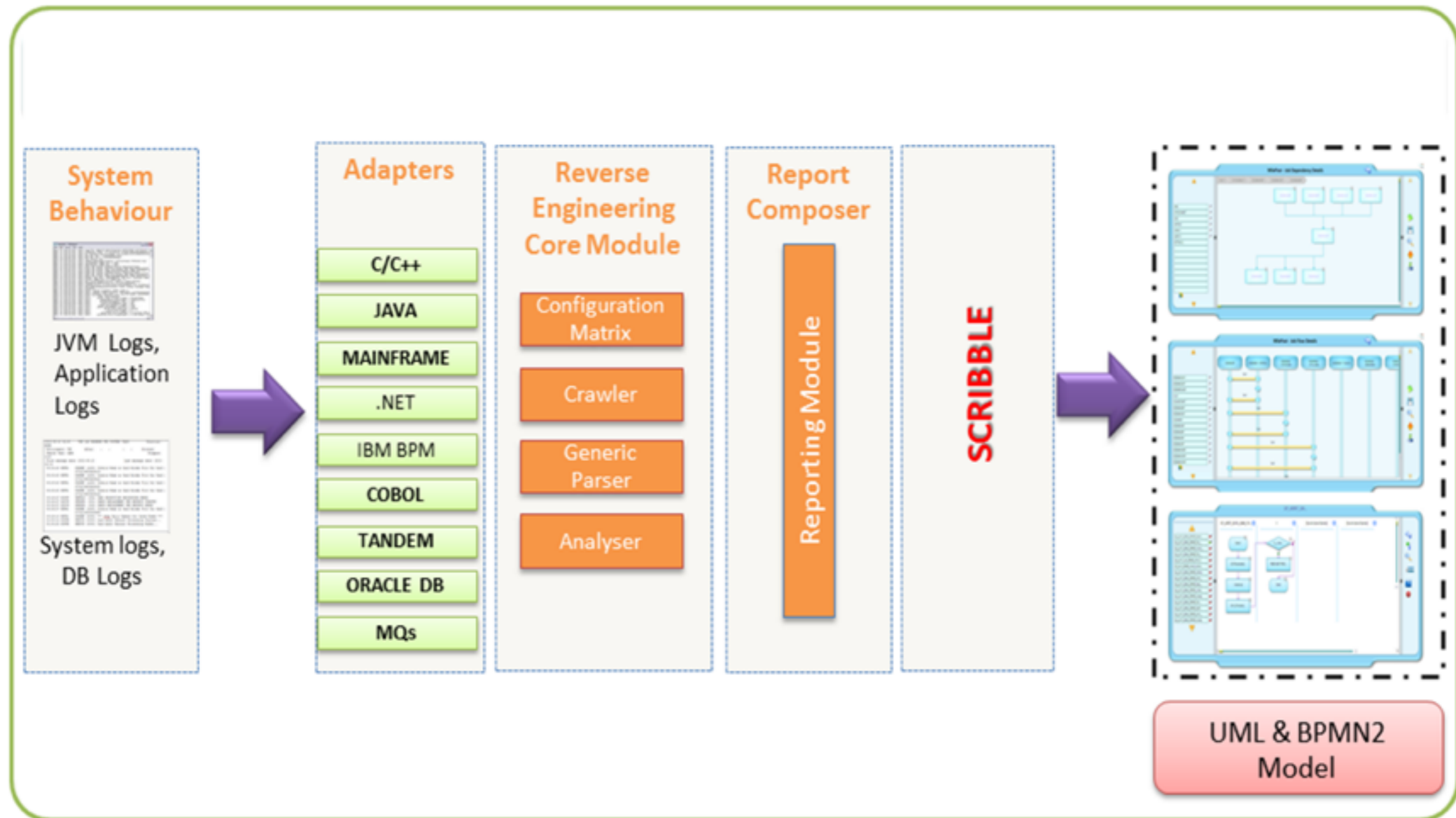

From Communicating Machines to Graphical Choreographies [POPL'15, CONCUR'15]

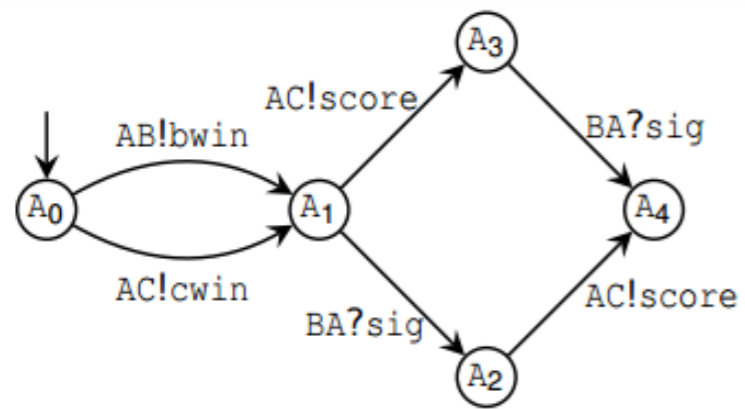

Alice

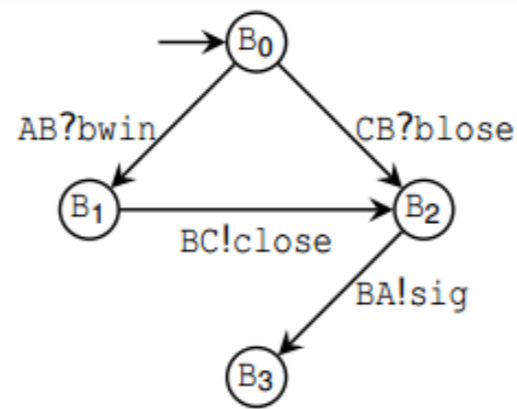

Bob

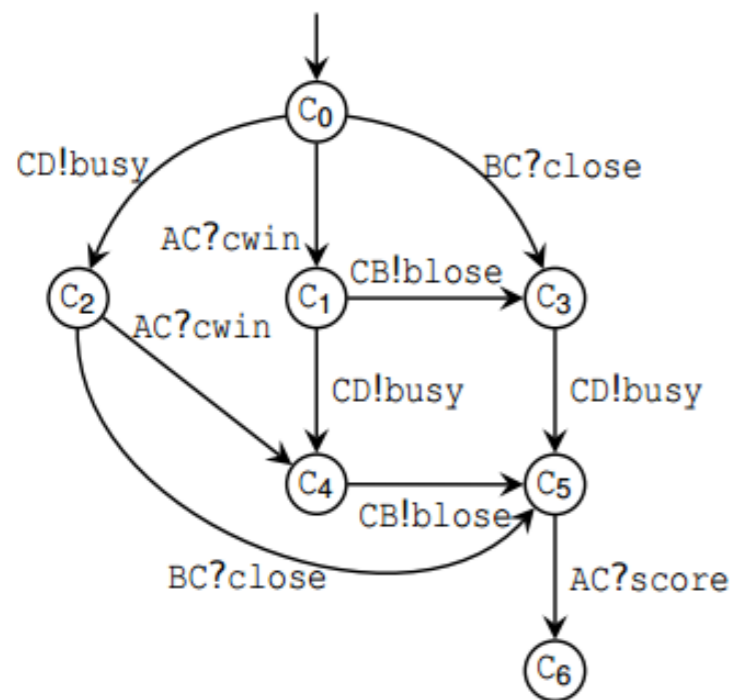

Carol

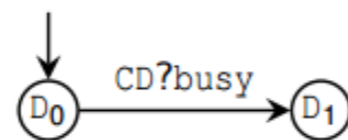

Dave

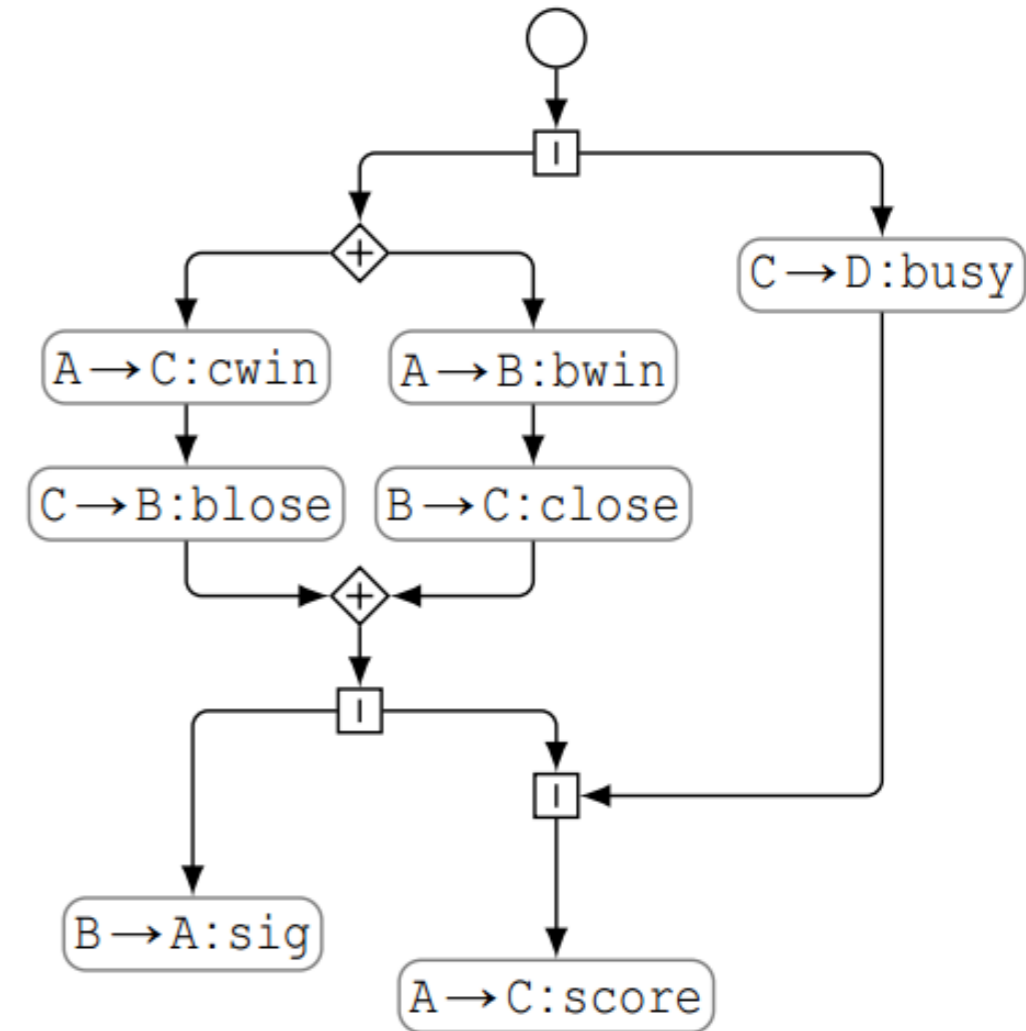

[ESOP'10, ESOP'12, CONCUR'12, CONCUR'14]

Go and Concurrency

- Developed by Google for multi-core programming
- Concurrency model built on CSP (process calculi)
- Message-passing **communication** over channels

" Do not communicate by sharing memory; instead, share memory by communicating. "

-- Effective Go (developer guide)

Contributions

- Static deadlock detection tool *dingo-hunter*
- Deadlock detection based on session types
- **Infer** session types as Communicating Automata
- **Synthesise** global session graphs from CA

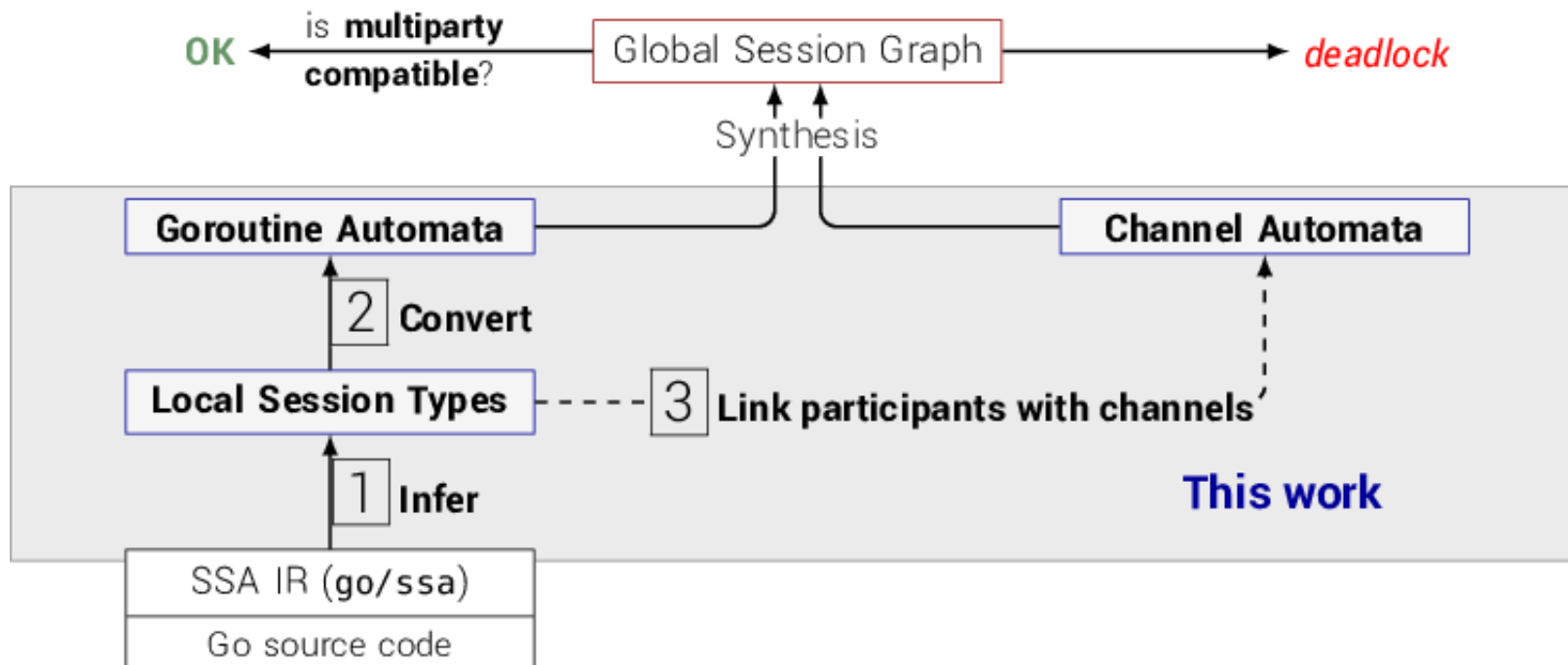

HAPPY

BIRTHDAY



FRANK